



Working Group on Losses Reduction

CIRED WG CC-2015-2

**Reduction of Technical and Non-Technical Losses
in Distribution Networks**

CIRED overview

Final report

20 / 11 / 2017

TABLE OF CONTENTS

Notice : this report constitutes a global document prepared by a number of contributors, but can also be considered as a collection of different complementary parts. Consequently, the different notations of the report (Tables, Figures, References) are relative to each part.

Table of Contents	2
Members of the Working Group.....	5
List of Acronyms.....	6
Summary of the report.....	8
1. Introduction.....	11
1.1. <i>Background and Scope of the Working Group</i>	11
1.1.1. Background on Distribution Losses	11
1.1.2. Scope of the Working Group	11
1.1.3. Structure of the final report	12
1.2. <i>Proceeding of the Working Group</i>	12
1.2.1. Data Collection	12
1.2.2. Report Elaboration.....	13
1.2.3. Feedback on Working Group proceeding	13
2. Definition of Power Losses	14
2.1. <i>General definition</i>	14
2.1.1. A physical definition of losses.....	14
2.1.2. Exceptions.....	14
2.2. <i>Technical Losses</i>	15
2.2.1. Variable Losses.....	15
2.2.2. Fixed Losses	16
2.2.3. Network services	17
2.3. <i>Non-Technical Losses</i>	18
2.3.1. Network equipment issues.....	19
2.3.2. Network information issues.....	20
2.3.3. Energy data processing issues	21
2.4. <i>Conclusions</i>	24
3. Measurement of Power Losses	26

3.1. Survey results.....	26
3.2. Measurement methods and distribution losses definition	28
3.2.1. Measurement of Distribution Network Losses (Level 1)	28
3.2.2. Measurement of TL-NTL detail (Level 2)	30
3.2.3. Measurement of losses factors (Level 3)	32
3.2.4. Complementary losses measurements (Levels 1 – 2 – 3).....	36
3.3. Conclusion.....	36
4. Technical losses	38
4.1. Introduction.....	38
4.1.1. TL definition (reminder).....	38
4.1.2. Objectives of the TL section	38
4.2. TL size in Distribution	39
4.2.1. Global view.....	39
4.2.2. Detailed view on TL	40
4.2.3. DSO concern on TL.....	42
4.3. Methods for TL mitigation	42
4.3.1. Component Replacement	42
4.3.2. Feed-In Control	45
4.3.3. Grid Management.....	48
4.3.4. Qualification of TL Mitigation Methods	50
4.4. Strategies for reducing TL	51
4.4.1. DSO use of TL mitigation methods (WG survey)	51
4.4.2. Global approach on losses	53
4.4.3. Smart-grid impact on losses	53
4.4.4. Techno-economic approach	54
4.5. Conclusion.....	56
5. Non-technical losses	57
5.1. Introduction.....	57
5.1.1. Definition (reminder of previous content)	57
5.1.2. Classification	57
5.1.3. Macro-economic environment/framework	59
5.2. Size of NTL.....	60
5.2.1. Global view.....	60
5.2.2. Detailed view	61

5.3. <i>Mitigation of NTL</i>	62
5.3.1. Main principles	62
5.3.2. NTL mitigation using data mining.....	63
5.3.3. NTL mitigation with smart meters	64
5.3.4. Mitigation of theft and fraud	67
5.3.5. Other measures.....	67
5.4. <i>Recommended methods of reducing NTL</i>	69
5.4.1 Global view.....	69
5.4.2 Effect of socio-economic conditions.....	70
5.4.3 Smart meter readiness	71
5.5. <i>Conclusions</i>	73
6. Regulation leverage.....	74
6.1. <i>Introduction: some questions about regulation of losses</i>	74
6.2. <i>An overview of the diverse DSO situations (survey results)</i>	74
6.3. <i>Analysis on losses regulation</i>	78
6.3.1. Theoretical regulation models.....	78
6.3.2. Possible regulation schemes	79
6.4. <i>Conclusion</i>	81
7. Appendixes.....	83
7.1. <i>Appendix on Technical Losses</i>	83
7.2. <i>Appendix on Non-Technical Losses</i>	94
7.2.1. More detail around NTL types and extent	94
7.2.2. Mitigation of NTL	98
8. References	108

MEMBERS OF THE WORKING GROUP

CONVENOR

Philippe DESCHAMPS, Schneider Electric, France (2015 – 2016)
Yann TORAVEL, Enedis, France (2016 – 2017)

SECRETARY

Bhargav Prasanna SWAMINATHAN, Grenoble INP (G2Elab), France

MEMBERS

Active Members and Contributors to the Report

Andreas BEUTEL, Eskom, South Africa
Raphaël CAIRE, Grenoble INP (G2Elab), France
Damien JEANNEAU, Sicame, France
Pedro MOUSINHO, Edp, Portugal
Giuseppe PANNUNZIO, Cesi, Italy
Nerea RUIZ, Iberdrola, Spain
Martin SAFANDA, CEZ Distribuce, Czech Republic
Massimo ZERBI, Enel, Italy

Associated members

Ramon CANTO, Endesa, Spain
Benoit KIRBA, Enedis, France
Wenpeng LUAN, Cepri, China
Evans POMA, Enel, Italy

COPYRIGHT NOTICE

Figures presented in this report have been collected from the referenced documents.

WARNING

CIREN gives no warranty or assurance about the contents of this publication, nor does it accept any responsibility, as to the accuracy or exhaustiveness of the information. All implied warranties and conditions are excluded to the maximum extent permitted by law.

The contents do not necessarily represent the views of the employers of the compilers of the report.

LIST OF ACRONYMS

A-C	Air-Conditioner
AC	Alternating current
AMI	Advanced metering infrastructure
AMM	Advanced Metering Management
CBA	Cost-Benefit Analysis
CHP	Combined Heat and Power
CVR	Conservation Voltage Reduction
DER	Distributed Energy Resources
DG	Distributed Generation
DMS	Distribution Management System
DR	Demand Response
DSO	Distribution System Operator
E	Energy
E-CIBS	Enhanced customer information billing system
EE	Energy Efficiency
EMPD	Expanded metal protection door
EMS	Energy Monitoring Systems
EU	European Union
FCFA	Franc CFA (Senegalese currency)
FIS	Fuzzy inference system
GB	Great Britain
GIS	Geographic Information System
GOES	Grain Oriented Electrical Steels
HRC	High risk customer
HTS	High-Temperature Superconductor
HV	High Voltage
IPC	Insulation Piercing Connector
ISC	Instantaneous Self-Consumption
IT	Information technology
LPC	Large (power) customer
LV	Low voltage
MV	Medium voltage
NM	Net-Metering
NPV	Net Present Value
NTL	Non-Technical Losses
OPC	Ordinary (power) customer
OPEX	Operational Expenditures
P	Power
PLC	Power line carrier
PV	Photovoltaic

RCD	Residual current device
RMR	Remote meter reading
ROI	Return On Investment
SEAL	Special Enforcement Against Losses (team)
SG	Smart Grid
SMI	Smart Metering Infrastructure (= AMI)
SVC	Support Vector Classification
T&D	Transmission and Distribution (of electricity)
TDR	Time domain Reflectometry
TL	Technical Losses
TOU	Time-Of-Use
UK	United Kingdom
USA	United States of America
VRES	Variable Renewable Energy Sources
WG	Working Group

SUMMARY OF THE REPORT

The reduction of distribution losses represents a specific issue for each DSO, due to heterogeneous levels of both technical (TL) and non-technical (NTL) losses, but also due to differences on definition, measurement or regulation of losses.

This reveals a real concern in proposing a global framework, which would be general enough to include all DSO situations about losses and specific enough to bring adapted answers to losses management.

In order to tackle these questions, CIRED has engaged a Working Group on the reduction of distribution losses, which proposes a three steps approach for 1. Measuring, 2. Managing and 3. Mitigating distribution losses.

Step 1 = Measure: Definition and Measurement of Losses

The definition proposed by the Group intends to guide the measurement of losses from a global perspective to a detailed perspective by source of losses and separately of other energies.

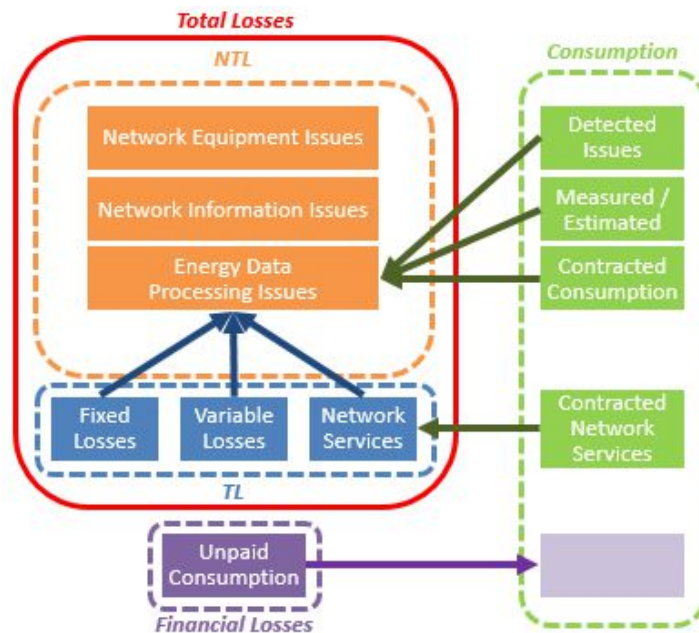

Figure 1: Relationships between losses and other energy categories

The consistency with regulatory principles was also taken into account in the definition, so that it can be applicable by DSOs. Only by ensuring this direct relationship between definition, measurement and regulation, will it be possible to efficiently quantify losses, both for benchmark purposes and for identifying mitigation actions.

	Level 1 : Global losses	Level 2 : TL / NTL detail	Level 3 : Detailed losses factors
Issue	Measure	Manage	Mitigate
Method	Energy balance	TL model (global) + Energy balance (level 1)	TL model (analytic) KPI & analyses on NTL

Figure 2 : Relationship between definition, measurement and regulation of losses

The effectiveness of the definition of losses can be confirmed by the main findings in the measurement methods for losses:

1/ **Operational measurement methods** can be elaborated for the three different definitions that have been proposed by the Working Group,

- These different measurement methods prove to be compatible and even complementary, with the possibility of combining them,
- This allows for a more precise focus on losses, giving some information on the main factors for losses.
- This can help find the best way to control them and to propose a solid basis for regulation approaches.

2/ **Smart meters** have an important impact on the measurement of losses for the 3 defined losses levels.

Through rigorous and virtuous approaches, measurement methods may be considered as one important basis of a global smart-grid approach.

Step 2 = Manage: Technical and Non-Technical Losses (TL and NTL) Management

Specific approaches are needed on TL and NTL management (and mitigation).

On Technical Losses:

1. The various examples analyzed in this report show that **TL structure and level are very specific** to each distribution network.
2. This report **classifies the methods for TL management** in three categories (Component / Feed-in-control / Grid Management) and identifies **two main issues**: methods that can be boosted by **smart grid approach** and question of geographic proximity and time synchronism for **DG impact on losses** (reduction vs increment).
3. As TL limitation is a complex equation with many variables, distribution system operators shall consider the different methods aiming to mitigate TL with a **technical-economic approach**, promoting network achievement at an optimized cost in developing countries and quality of supply rather than losses in developed countries.
4. **Regulation is a key factor** to solve this difficulty, in favoring cooperation between stakeholders and adopting a more global approach. In particular, tariff may provide DSO a long-term financial framework with favorable incentives (e.g. on specific research programs on the field of smart grid).

On Non-Technical Losses:

1. The conditions and environment **specific to each DSO** need to be considered, as these may alter the most effective NTL measures from those listed for different scenarios in this document (classified between local / global and internal / external measures).
2. The limited experience with **smart technologies** in this application is that they are in principle very good at tackling NTL. However, for them to be successful the business

processes and funding need to be in place within the DSO and correctly adapted to adequately support this.

3. The **regulatory and general socio-economic conditions** in the country need to be able to support smart technologies and their use does not alleviate the need to also pursue non-technical (traditional) measures such as fostering good customer relationships, regular community engagements, law enforcement and the like.

Step 3 = Mitigate: Regulation Role in Mitigation of Losses

As far regulation is concerned in mitigation of losses, some key factors can be underlined, as choosing a common definition to all DSO and adopting a relevant regulation fit to losses level and structure.

This report has also identified some good practices for losses regulation, as the need of a preliminary study before defining a global strategy and an action plan, especially for choosing between a global regulation on losses (volumes and prices) and a more specific approach.

The economic decisions of a DSO, in general, encompass many other factors apart from losses. However, losses have to be part of the equation, either as a cost that is leveraged (when the decision helps reducing losses) or as a cost that is borne (in all other cases). Consequently, regulation has a major role in guiding and facilitating choices, not in penalizing or “punishing” a DSO.

In the global sense, loss regulation should always consider the views of all concerned stakeholders, be it for mitigating energy theft, reducing distribution bills, or for increasing energy efficiency.

In this point of view, regulation of losses can be seen:

- Inside DSOs, as a key decision factor for global economic decisions and process optimization.
- Outside DSOs, as a way for measuring, controlling, and optimizing electric flows, considering their cost for the global electric system.

As a conclusion:

This CIRED report proposes a global method for reduction of losses, which can be adapted to each DSO situation. It highlights two key findings indicating that (i) TL and NTL mitigation requires different and specific approaches, and that (ii) “Smart” and regulation shall be boosters, in support of “traditional” approach.

This large overview on losses issues does not claim to be exhaustive, nor a definitive view on the subject, but is more a guideline for every actor that would aim at reducing losses on distribution networks. The global approach presented in this report shall be illustrated, completed and questioned by any concrete experiences on losses mitigation. It is also a rich field for R&D applications in the distribution area, which can extend this CIRED working-Group realization.

Yann TORAVEL, convenor of the Working Group, October 2017

1. INTRODUCTION

1.1. BACKGROUND AND SCOPE OF THE WORKING GROUP

1.1.1. Background on Distribution Losses

Regarding distribution networks, annual electricity losses are on average at about 2 to 12% in the European Union countries according to ERGEG Position Paper on Treatment of Losses by Network Operators. In the same time, the European Energy Efficiency Directive (Art. 15.2) requires all Member States to assess the potential for energy efficiency and to specify measures to improve it. Losses reduction becomes a real stake for all European countries.

Last developments in technologies bring several promising solutions contributing to a full process improvement. For instance, smart metering roll-out and availability of new sensors make potentially available a large number of operational data on the grid; IT and data mining techniques make possible to manage such a huge volume of data to assess and locate losses; and many interesting tracks are on investigation to reduce losses, either based on new components or innovative operation mode.

In order to tackle these questions, CIRED has engaged a Working Group on the 2015-2017 period, whose subject was the reduction of distribution network losses.

1.1.2. Scope of the Working Group

The working group has focused first on distribution networks in European countries but has also enlarged the analysis to the rest of the world, depending on the available information.

The first objective of the group is to deliver an overview of the main challenges regarding losses assessment and reduction. It took into account the recent evolutions in the network, in a technical point of view (more Distributed Energy Resources connected for instance) and regulatory point of view (European Directive for instance). It included all kind of losses, technical and non-technical.

The second objective is to deliver an overview of existing and emerging solutions taking into account last available technologies.

As agreed with the CIRED Committee, the group's activities have been broken up as follows:

1. Identify the different methodologies currently used to value both technical and non-technical losses
2. Identify the main regulatory frames and corresponding incentives and roadblocks
3. For different networks, write the "state-of-the-art" principles to identify, locate and limit losses.
4. Based on ERGEG position paper, identify and benchmark best practices for losses treatment
5. Describe and position emerging techniques and methods to reduce losses in their application framework justified.

1.1.3. Structure of the final report

The group has set up different work packages, dealing with each expected issue on losses.

This report consists of 5 parts, which are constituted by the main results of each WG package:

- Definition of power losses (section 2)
- Measurement of Power losses (section 3)
- Technical Losses (section 4)
- Non-Technical Losses (section 5)
- Regulation leverage (section 6)

The report is completed by:

- A global introduction (section 1)
- Appendixes on Technical Losses and Non-Technical Losses
- A references section relative to each WG package

1.2. PROCEEDING OF THE WORKING GROUP

1.2.1. Data Collection

The Working Group has started with the collection of significant bibliographic information for each WG package. It has led to a first identification of state-of-the-art and key questions on losses.

Then, the Working-Group has set up brainstorming meetings in order to elaborate a survey on distribution power losses with WG member's experience. This WG survey has been sent to CIRED members, who contribute to complete it, with the help of relevant experts. At the end, 20 answers were collected, mainly in European countries (12 answers) and also in countries out of Europe (5 answers in America and 3 in Asia). The Working-Group wants to thank all the actors that have spent their time and helped to fulfil this survey, which has been a key input for the report.

Europe										
Finland	Sweden	Austria	Netherland	Czech (2)	Slovaquia	France	Italy	Portugal	Spain	UK

America		Asia		
Brazil (2)	USA (3)	Japan	China	Indonesia

Table 1: List of countries (and DSO) answering WG survey on distribution losses

Afterwards, the results of WG survey have been crossed with bibliographic materials in order to answer CIRED questions on losses: global definition, state of the art, emerging technical and regulatory solutions.

1.2.2. Report Elaboration

This work of data collection has first been initiated on specific issues, amongst each WG package, and then aggregated in the report in a global and coherent approach (Cf. Figure 1).

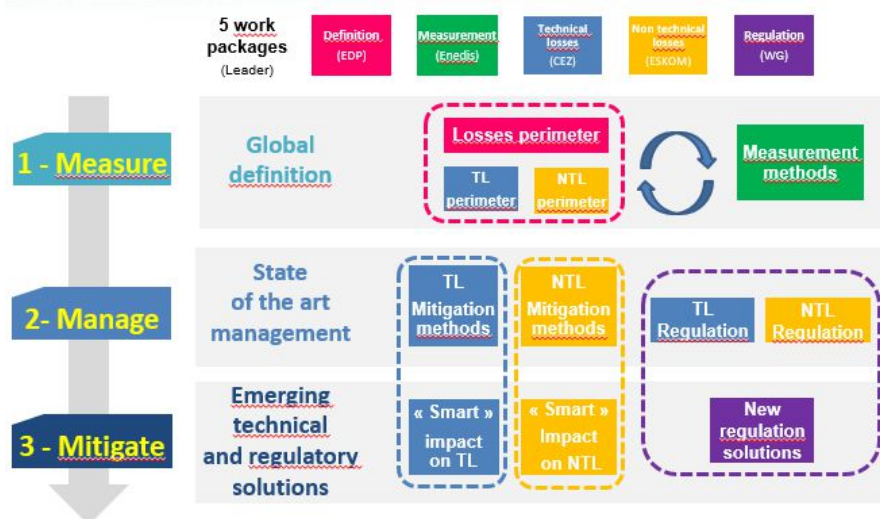

Figure 1: From WG packages analysis to report elaboration

In the end, the report reflects this global approach on losses (from measurement to mitigation), but also respects the WG organization in work packages, in order to propose an “à la carte” approach for the reader.

1.2.3. Feedback on Working Group proceeding

The Group has proceeded through WG packages, with a package leader and experts who could contribute to different WG packages according to the topics. The global organization and the coherency between packages were guaranteed by the WG convenor, helped by the WG secretary.

This collective organization, which enabled a large and relevant overview on losses issues, was a key factor for both data collection and report finalization steps.

Thus, the Working Group would not have achieved this report without CIREN support:

- The Group relied on CIREN organization for collecting a large bibliography on losses and for distributing the WG survey, which were key inputs,
- The annual CIREN workshop or conference offered great opportunities for WG meeting, but also for profitable exchanges with peers and CIREN committee,
- The round-table organized in 2017 CIREN Conference was a first occasion to present the results of the Group and to have a large exchange on distribution losses issues.

More globally, this Working Group approach has constituted a very rich and stimulating experience for each member and has proved to be a powerful way to animate CIREN community.

2. DEFINITION OF POWER LOSSES

2.1. GENERAL DEFINITION

2.1.1. A physical definition of losses

The definition of losses vary significantly from country to country as a consequence of the wide range of sources for power losses. This leads to a situation where there is no common definition of losses. For benchmarking purposes, this circumstance seriously hinders the analysis of percentages of losses across countries. An important step to being able to compare losses across network operators would be the adoption of a common standard for the definition of losses [1].

Distribution network losses can be broadly defined as the difference between the electrical energy entering the distribution network, from embedded generators or upstream / same level / downstream networks, and the electrical energy exiting it, for consumption purposes and properly accounted for, in percentage terms for a particular period [1][3][7][10].

Distribution network losses are conventionally broken down into two categories:

- Technical losses;
- Non-technical losses.

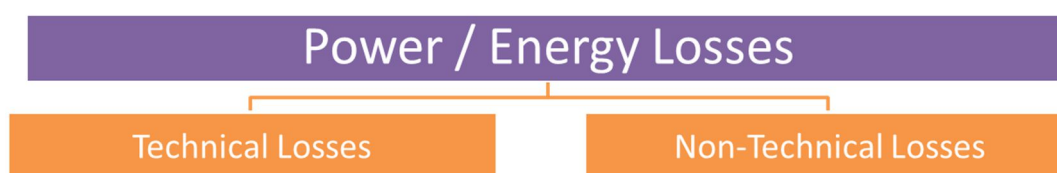

Figure 1: Repartition of power losses

2.1.2. Exceptions

It should be emphasized that the focus of the present work is power losses or energy losses (and not economic losses) that are part of the physical energy balance of a given network. Taking this into account, and according to the above definition, two particular situations that are commonly considered as part of losses are excluded:

1. Energy consumed by network equipment, provided that there is a contract between the distributor and the retailer to supply the consumption, is excluded from technical losses since it is consumed energy, not dissipated energy, and it can be properly accounted for, either measured or estimated;
2. Billed but unpaid consumptions are excluded from non-technical losses since in this case the consumed energy is properly accounted for by distribution operators and can be set apart from physical energy balance.

Although the general definition of losses presented above is about physical balance, the reality is that it depends on the regulatory context and the available data. Presently, the calculation

of losses is usually performed with data collected from the billing process, thus leading to the need of making two exceptions in the definition:

1. Whenever it is not possible to establish a contract on a network equipment, the consumptions are considered as part of technical losses;
2. Unbilled consumptions, even when they are known and properly accounted for, but without a contract and a supplier to bill, are considered as part of non-technical losses.

2.2. TECHNICAL LOSSES

Technical losses in power systems occur naturally as they consist of energy dissipation in electrical system components such as lines, transformers, connections, measurement systems and other equipment that carry energy to and from customers [3][12]. Technical losses are also called 'Physical losses' as they refer to energy transformed to heat and noise while distributing electricity and, therefore, physically lost. This energy dissipation costs customers money and contributes to carbon emissions [1][2][17].

Technical losses occur as a direct result of the physical characteristics of the electrical equipment used in distribution networks [3]. They depend on the design of the power grid, the voltage and transformation levels and the length of the power lines. Technical losses relate to investment in equipment (lines, transformers) and long term signals (compromise between investment costs and operational expenditure). They also relate to efficient planning and the design of distribution networks [1].

Technical losses can be further divided, into:

1. Variable losses (load related);
2. Fixed losses (not related to load);
3. Network services (uncontracted consumptions of network equipment).

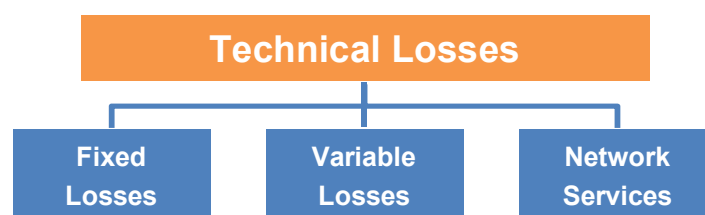

Figure 2: Types of Technical Losses

2.2.1. Variable Losses

All conductors, whether they are coils in transformers, aluminium or copper wires in overhead lines or cables and even in switchgear, fuses, or metering equipment, have an internal electrical resistance which causes them to heat when carrying electric current [6]. Since energy losses stemming from the dissipation of heat to the environment vary with the current flowing through conductors in electrical networks, these losses are called 'variable losses' [1]. These losses are also usually referred as '*ohmic losses*', '*copper losses*', '*Joule losses*' or '*resistive losses*' [2][12].

As a result of variable losses changing as power flows increase and decrease (proportionally to the square of the current), transmission networks experience a lower level of losses because at higher voltages a lower current is required to transmit the same amount of electric power. Conversely, distribution networks (at lower voltages) are subject to a higher level of losses [1]. Additional factors such as the effect of network imbalance, power factor and power quality can also have an impact on variable losses, as they influence the value of the currents flowing through conductors [4][7].

Additionally, variable losses are also dependent on the length and the cross section of the conductor as they vary in proportion to the resistance [1]. The resistance of a conductor decreases as its cross sectional area increases [7]. Therefore, the effect of losses is reduced with larger cable sizes. A similar principle also applies to the variable losses in transformers, where the cross sectional area of windings, and the materials used in them, influence the variable losses. Inadequate connections between network equipment and deteriorated conductors can also be a source of this type of losses, as they can cause the arising of hot spots due to an increase in the equivalent resistance [2][16].

In general, variable losses contribute roughly between two-thirds and three-quarters of the total power system technical losses [2]. In essence, measures to reduce variable losses can be classified under two main influencing factors (power flows and resistance) and how they apply in the global system: they either aim to lower the system power flows or to lower the resistance of the transportation paths. A reduction in the utilization levels of network assets can contribute to lower both current and resistance. However, increasing network capacity leads to higher capital investments. This leads to a direct trade-off between cost of losses and capital expenditure. It has been suggested that optimal average utilization rate on a distribution network that considers the cost of losses in its design could be as low as 30 per cent [6][16].

2.2.2. Fixed Losses

Some electrical energy is dissipated by network components and equipment such as transformers or conductors as a result of being connected to the network and made 'live' (energized) [3]. Even if no power is delivered to customers, the system has losses just because it is electrically energized [6]. These losses take the form of heat and noise and are called 'fixed losses' or 'no-load losses', because they are independent of how much electrical energy the network delivers [16].

Transformers' energization are responsible for the majority of the fixed losses (although this equipment also give rise to variable losses as referred in section 2.2.1). These losses occur in the transformers' core and are called 'core losses' or 'iron losses'. Two types of core losses are known to exist [12][6]:

- 'Hysteresis losses' are losses that stem from the reversal in magnetic polarity of the steel in transformer cores in every AC cycle. This causes the material to pulse (which emits a humming noise) and to heat up.
- 'Eddy current losses' are losses that stem from the circulation of induced currents in conducting parts that are not copper windings, such as the iron body or steel core of the transformer.

Besides transformer inefficiency, another source of fixed losses is the electrical insulation in network equipment. Imperfections in electrical insulation lead to the flow of infinitesimal currents across them in transformers, lines, cables, and other network equipment. These type of fixed losses are called 'dielectric losses' or 'leakage current losses' [16]. Corona losses, a particular case of these type of losses, occur in high voltage and mainly in extra high-voltage lines. They vary with the voltage level, the physical wire diameter, and with weather conditions such as rain and fog [2]. Corona losses can generate audible and radio-frequency noise and is often seen as a glow in the air adjacent to conductors. They generally contribute to a very small percentage of the overall fixed losses [6].

While fixed losses do not change with current, they depend on the applied voltage. However, as the applied voltage is relatively stable while the network equipment is energized, they are essentially fixed [7]. Therefore, fixed losses are a function of the network itself and depend mainly on the number of energized components. In this respect, measures to reduce fixed losses mainly aim to reduce the number of energized components or to increase their efficiency. In general, fixed losses contribute to roughly between a quarter and a third of the total technical losses on distribution networks [2].

2.2.3. Network services

Besides the equipment responsible for the dissipation of energy as fixed and variable losses, other equipment connected to the network may consume energy. In this section, only the consumptions to which a contract is not possible to establish are included (section 2.1.2). Network control and measuring elements installed along electrical lines or meters in customer facilities, either mechanic or electronic, are examples of uncontracted consumptions.

The separation of this type of network consumption from the technical losses related to energy dissipation allows to exclude them from some international benchmarks relative to the fix and variable losses part. Indeed, losses consumptions due to network equipment have both a fix component (e.g., for permanent use) and a variable component (e.g., depending on communication devices according to data frequency and volumes).

Whenever a contract is possible and effective on network equipment (e.g., auxiliary services, future storage capacities), their consumption is excluded from losses and considered as normal consumption. The consideration of whether or not there is a contract behind this consumption is justified with the regulatory context and the source of data frequently used for losses calculation (billing system).

2.3. NON-TECHNICAL LOSSES

In addition to technical losses, not all of the energy delivered through the distribution network and consumed by end users can be measured or otherwise properly accounted-for. These additional losses also present themselves as 'lost energy'. This unaccounted-for proportion of the losses is known as non-technical losses. These losses are also referred to as 'black losses' or 'commercial losses', since they are socialized and not directly charged by suppliers or distribution companies [1][3].

Non-technical losses primarily relate to unidentified, misallocated, and inaccurate energy flows. In essence, they represent the amount of energy that is delivered but not accounted for. It is important to separate non-technical losses from two cases: energy accounted for but not billed, or energy billed but where the bills are not paid. In both cases, the entity consuming the energy is known. However, in the case of non-technical losses, the end user is unknown, or the amount of energy being consumed is uncertain [6].

Non-technical losses are caused by actions that are external to the power system [12]. They refer to lost energy that is not directly related to the transportation of electricity and occur independently of the physical technical characteristics of the network (technical losses) [3][7].

Non-technical losses can also be viewed as undetected load of customers that the utilities don't know. When an undetected load is connected to the system, the actual losses increase while the losses expected by the utilities will remain the same. The increased losses will show on the utilities' accounts, and the costs will be passed along to the customers as distribution charges [11].

There is a wide range of situations that create non-technical losses. In all the cases, a poor level of management of the utility operating the network is to blame [13]. Non-technical losses are often related to the customer management process [12] and can be divided into the following categories:

1. Network equipment issues;
2. Network information issues;
3. Energy data processing issues.

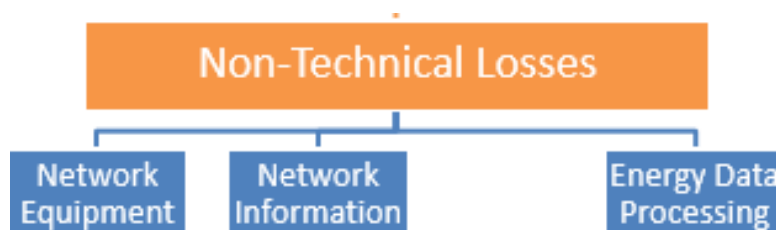

Figure 3: Types of Non-Technical Losses

2.3.1. Network equipment issues

The wide variety of factors related to network equipment issues that contribute to non-technical losses can be classified according to the following main causes:

- Theft and fraud, due to illegal interference with network assets;
- Measurement errors, due to inaccuracies in measurement equipment.

Theft and fraud

There are several ways in which electricity can be drawn from the network illegally [3]. Theft and fraud are believed to account for a majority of the non-technical losses in power systems [12]. They are important challenges for the electricity industry, and require a concerted effort from a range of stakeholders to mitigate them [6]. In addition to theft and fraud, there are serious safety aspects to be considered. It is difficult to gauge the exact extent of this type of losses as a large proportion of it is likely to go undetected [1].

Theft is defined as any illegal abstraction of electricity for use other than at premises where any metering points or metering systems are registered by a supplier. It can occur where an unauthorized connection to the network is made or where illegal re-connection takes place (e.g. after a formal disconnection). It can also sometimes occur where the connection process is incomplete [3].

Fraud is the illegal abstraction of electricity within the boundary of a customer's property [3]. All metered customers purchase electricity from a supplier and are associated to a registered meter point. Fraud happens as a result of an ill-intentioned and illegal manipulation of the meter, by tampering or bypassing the meter [9]. In both cases, the aim is to make the meter record a lower amount of energy than is actually consumed [11].

Measurement errors

Non-technical losses due to measurement errors are defined as the difference between the amount of energy actually delivered through the meter and the amount registered by the meter or read from it. They can occur for the following reasons [11][12][15]:

- Uncertainty of measurement equipment;
- Errors in manual or automatic meter reading;
- Defective measurement equipment;
- Incorrect installation or configuration of measurement equipment;
- Measurement equipment breakdown.

Although measurement equipment breakdown can be uncommon, e.g. equipment struck by lightning, equipment damaged over time, neglected equipment or no equipment maintenance, it can induce an overuse of electricity, thus causing the increase of non-technical losses [12][17].

2.3.2. Network information issues

Situations arise where energy is delivered and consumed but is not accurately recorded due to inaccuracies in the distribution network database, effectively becoming lost energy. Typical reasons for inaccurate or missing consumption data due to this type of non-technical losses include [1][7]:

- Missing or unregistered connection points;
- Incorrect location or energization status of connection points;
- Incorrect information of measurement equipment.

Missing or unregistered connection points

These anomalies especially concern the IT reference system used for physical (or contractual) energy balance and for estimation of losses. According to each DSO, they may refer to the billing system, the meter data management system or the GIS system.

Incorrect location or energization status of connection points

Incorrect location of connection points do not directly create non-technical losses at the global level, but may do on sub-levels (e.g., for regional or unit losses estimation).

Incorrect energization status can contribute to non-technical losses when there is a site recorded on the distribution network database but has no supplier appointed to it. If this site is connected and drawing electricity from the grid, but no supplier is billed for this electricity, it should be included as losses [1].

Unbilled accounts can occur due to the move-in / move-out process (switching supplier) where some energy may be temporarily consumed without contract, and without correct registration. Another situation where the consumption should be included as a part of these losses is when a site is disregarded from meter reading and billing due to its incorrect energization status.

Incorrect information of measurement equipment

Non-technical losses due to incorrect information of measurement equipment can occur when correction factors are incorrectly introduced in the meter data management system (losses factor when the meter and the DSO-customer boundary are located in a different voltage level, current transformer relation factor, etc.).

2.3.3. Energy data processing issues

Inaccuracies may occur while processing energy data for the assessment of losses, often related to errors in the estimation of energy consumed or produced. These errors that arise in the calculations contribute to non-technical losses and can occur due to the following reasons:

- Estimation of unmetered consumptions;
- Estimation of consumptions between meter readings and calculations;
- Estimation of technical losses;
- Estimation of detected issues;
- Other energy data processing issues.

Estimation of unmetered consumptions

Not all supplies in distribution networks are metered [6]. There are many items of electrical equipment where it is neither practical, nor cost-effective, to measure energy consumption using conventional meters [3]. In these circumstances, there are legitimate unmetered supplies whose energy demand is estimated rather than accurately metered [7].

Every unmetered consumption can be treated as any other type of load, provided that it is registered, properly estimated and accounted for [1]. Moreover, customer-related unmetered consumptions (e.g. public lightning) or some DSO's own consumption (e.g. auxiliary services of substations) can be adequately contracted from an energy supplier and paid for by regular tariffs as any other normal consumption. Therefore, unmetered consumption, whether related to customers or the DSO, can be excluded from non-technical or technical losses, respectively, provided they are adequately contracted. Only the difference between the real and estimated unmetered consumptions is part of non-technical losses.

Some countries have effectively combated certain sources of non-technical losses either by installing meters or estimating consumption (with payment of a lump sum) for some consumption points, thus avoiding the community having to support this energy supply [1].

Generally, unmetered consumption can be of two types: costumers' consumptions and own consumptions. They are described below:

- Unmetered customers are normally made up of a large number of smaller un-metered connections [3]. Typical unmetered costumers' consumptions include public lightning, traffic lights, road signs, lighting in shared occupancy buildings (often public sector), bollards, car-park lighting, automatic vehicle number plate recognition, car-park ticket machines, phone boxes, communication cabinets, etc. [6]. There are also facilities where transitory arrangements still apply, e.g. temporary installations for public events [1]. In some countries, agricultural consumption or rail traction can also be unmetered supplies [12].
- Own consumptions account for the electric energy used by the distribution utility in the regular operation of the network. Inside substations, energy is typically consumed for auxiliary services such as heating and cooling, lighting and security, dehumidification, transformer cooling, protection and control, battery charging, measurement equipment (more important in the case of smart-meters because, as their functionalities are more

sophisticated, they use more energy than non-smart meters do), oil pumps, air compressors, etc. [4][7][16]. Offices, warehouses and workshops are other facilities related to network operation where unmetered consumptions can occur [18].

Unmetered energy can be quantified by establishing accurate records for each unmetered consumption (equipment inventories) and applying a representative demand profile (or combining the power of each load and its time of operation), to estimate consumption characteristics [5][6]. This information enables the total estimated energy to be accounted for, and provides the basis for both billing and for loss calculation [3].

Non-technical losses associated with unmetered supplies can be attributed to any inaccuracy in the information of the unmetered equipment connected to the network, such as incomplete database records of unmetered loads, inaccurate equipment inventories and errors regarding the assumed demand characteristics [6]. If, for example, a number of street lighting columns are missing from the information records, then the energy used in these lamps will be accounted for as network losses (non-technical losses). Records can become inaccurate if the party responsible for populating them loses track of what is installed, removed or modified [3].

To minimize inaccuracies in the information of unmetered consumptions, actors are required to hold accurate inventories of their unmetered equipment. The estimate of annual energy consumption should be updated every year and subject to numerous quality checks to help ensure all unmetered energy is accounted for. This is important as the cost of all losses, including any unknown unmetered supply, are paid for by the customer [3].

Estimation of consumptions between meter readings and calculations

Losses are usually calculated for a well-defined time period, for instance, a month or a year. Therefore, inaccuracies in the calculation of losses may occur if data collection time of input meters differs from data collection time of consumption meters [1]. This is often called “cut-off” effect. A classic case occurs when the calculation of losses comprises consumers without daily or hourly meters and time-lags exist between meter readings and the period of losses calculation. Estimations of consumptions are necessary in these cases, with the consequent inaccuracies that contribute to non-technical losses [10].

Estimation of technical losses

Non-technical losses are more difficult to measure than technical losses because they result from behavior that is not always known, or accounted for, by distribution operators. Normally, non-technical losses are calculated as the energy which is not able to be accounted for once technical losses have been fully considered [3]. Therefore, the accuracy of the estimate of non-technical losses is dependent on the accuracy of the estimation of technical losses [18]. This means that if there are real power flows or conditions that technical loss computations fail to take into account, the inaccuracies that arise also contribute to non-technical losses [7][12].

Inaccuracies in the assessment of technical losses that may cause the increase of non-technical losses are related to disregarded or unknown situations, such as equipment deterioration over time, network imbalance, approximate load / generation diagrams or inaccurate network equipment modelling [12].

Estimation of detected issues

Finally, when an issue related to non-technical losses is detected, the corrected past consumption can be estimated in order to improve the assessment of losses relative to the current period of calculation. Therefore, a detected issue, e.g. a detected theft, provided that the detection is achieved during the period of calculation and that the process accept such corrections, shall be excluded from non-technical losses and only the differences between the real and estimated consumption is part of non-technical losses.

One may consider that detected issues bring a “corrected energy” that reduce the current losses calculation, but also bring a “secured energy” for next period of calculation.

This procedure can be applied to the issues mentioned above, i.e.:

- Network equipment issues;
- Network information issues;
- Energy data processing issues.

Other energy data processing issues

Other energy data processing issues can result in miscalculations and record keeping errors, contributing to the increase of non-technical losses [12][13].

As these miscalculations and errors result from the loss estimation process and not from the initial consumptions on the network, this kind of non-technical losses are often called “internal” or “administrative” losses by difference with the other kinds of non-technical losses called “external” or “customer” losses.

2.4. CONCLUSIONS

In the following table it is shown a resume of the definition presented above.

Level 1	Level 2	Level 3	Components of Level 3
Losses	Technical Losses	Fixed Losses	<ul style="list-style-type: none"> • Hysteresis losses • Eddy current losses • Dielectric losses
		Variable Losses	<ul style="list-style-type: none"> • Ohmic losses
		Network Services	<ul style="list-style-type: none"> • Uncontracted consumptions of network equipment
	Non-Technical Losses	Network equipment issues	<ul style="list-style-type: none"> • Theft and fraud • Measurement errors
		Network information issues	<ul style="list-style-type: none"> • Missing or unregistered connection points • Incorrect location or energization status of connection points • Incorrect information of measurement equipment
		Energy data processing issues	<ul style="list-style-type: none"> • Estimation of unmetered consumptions • Estimation of consumptions between meter readings and calculations • Estimation of technical losses • Estimation of detected issues • Other energy data processing issues

Table 1: Proposed definition of losses with 3 combined levels

The next figure (Cf. figure 4) precises relationships between losses and other energy categories.

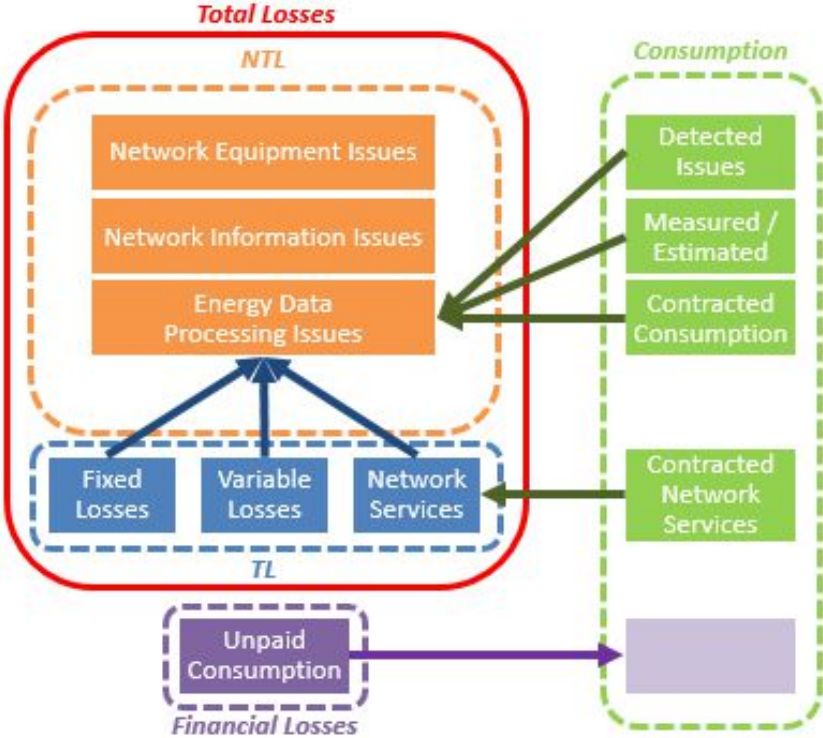

Figure 4: Relationships between losses and other energy categories

With the proposed definition, it is intended to guide the measurement of losses from a global perspective to a detailed perspective by source of losses. The consistency with regulatory principles was also taken into account in the definition, so that it can be applicable by DSOs. Only by ensuring this direct relationship between definition, measurement and regulation, will it be possible to efficiently quantify losses, both for benchmark purposes and for identifying mitigation actions. These questions are addressed in the following sections.

3. MEASUREMENT OF POWER LOSSES

The first part of the report has proposed a combined definition for losses with three different levels. It is now important to check how effective these definitions can be:

- The first key question is the possibility to have a concrete measurement method which may be applied according to each selected vision of losses (Level 1 : Global losses ; Level 2 : Technical / Non-technical repartition of losses ; Level 3 : Detailed losses by origin)
- The second key question is the way smart meters may contribute to losses measurement, by improving accuracy or reducing its cost
- The third key question is to precise how these 3 definitions may exist simultaneously and with coherency, in order to allow a global losses level estimation for a DSO, both for external benchmark (losses value and %) and for mitigation actions (losses gain evaluation).

These questions will first be approached with the WG survey results on DSO practices for losses measurement. Then, the proposed definition for losses will be analyzed more precisely according to these questions and with the objective to identify some ways to favour an effective losses measurement, whatever the DSO situation.

3.1. SURVEY RESULTS

The CIRED WG survey has collected information on distribution losses within about 20 DSO around the world (with a majority in Europe). The following results reflect their aggregate answers on measurement issues.

The tables reconstitute only the expressed answers, including some precisions when available. The results are completed by a short analysis, which tries to make a link with the different proposed losses definitions.

The complete and detailed answers to survey are presented in Survey Appendix.

Measurement issues

All the surveyed DSOs have an internal evaluation of losses in their financial or operational process (table 1), which is a good basis for estimating the global losses volumes (Cf. level 1 definition).

Question	Yes	No
Is there an overall assessment of the losses occurring on the distribution grid you are responsible for?	17	-

Table 1: Survey question on losses overall assessment

A minority of questioned DSOs answered positively to this question, amongst DSO with high concern on NTL (in southern Europe, in Asia and America). The other DSOs claim to have no financial or operational KPI for losses (for many DSOs, these KPIs may not be formalized).

These indicators would be a good practice, in order to have comparable figures on losses (benchmark, control) and to measure the efficiency of losses mitigating actions (Cf. level 3 definition : losses key factors).

Question	Yes	No	N/A
Are there standardized indicators on losses that are monitored?	7	6	5

Table 2: Survey question on standardized indicators on losses

Control issues

About two thirds of the surveyed DSOs estimate losses with a distinction between TL – NTL (Cf. level 2 definition)

Question	Yes	No
Can you differentiate between technical and non-technical losses?	11	5

Table 3: Survey question on TL / NTL distinction

Energy balances are used by a majority of DSO, sometimes detailed between TL and NTL (ICf. levels 1 and 2 definition).

Question	Global	With detail TL - NTL	No
Are TL and NTL measured or estimated by an Energy balance ?	8	4	2

Table 4: Survey question on estimation by energy balance

TL estimation issues

The losses assessment is achieved in terms of energy for a large majority of DSOs. It is additionally in terms of peak power for many DSOs, notably for those with a high concern on fixed losses (e.g., in Northern Europe and China).

Question	Yes	No
Is the loss of energy (Wh) considered in the impact evaluation ?	15	2
Is the loss of power (W_{peak}) considered in the impact evaluation?	6	10

Table 5: Survey question on impact evaluation in energy and power

Survey key findings

The survey answers reflect the diversity of DSO views for loss definition and justify the proposed definition of losses with 3 combined levels.

3.2. MEASUREMENT METHODS AND DISTRIBUTION LOSSES DEFINITION

3.2.1. Measurement of Distribution Network Losses (Level 1)

General Principle

As indicated in definition section (2.1), Distribution Network Losses are defined as the difference between the energy entering and exiting an electrical network.

The measurement method reflects this definition :

ENERGY LOSSES = SUM of ENTERING ENERGIES – SUM of EXITING ENERGIES

ENTERING ENERGIES = All the electrical flows entering the network

- Energy flows from TSO or DSO (either situated on upper, same or even lower voltage level)
- Energy flows from embedded generators on DSO networks (local DG)

EXITING ENERGIES = All the electrical flows exiting the network for consumption purposes

- Energy flows to TSO or DSO (either situated on upper, same or even lower voltage level) when local production flows excess consumption flows
- Measured or estimated energy flows from contracted sites (including in-house consumption, public lighting, ...) as defined in the previous part of this report.

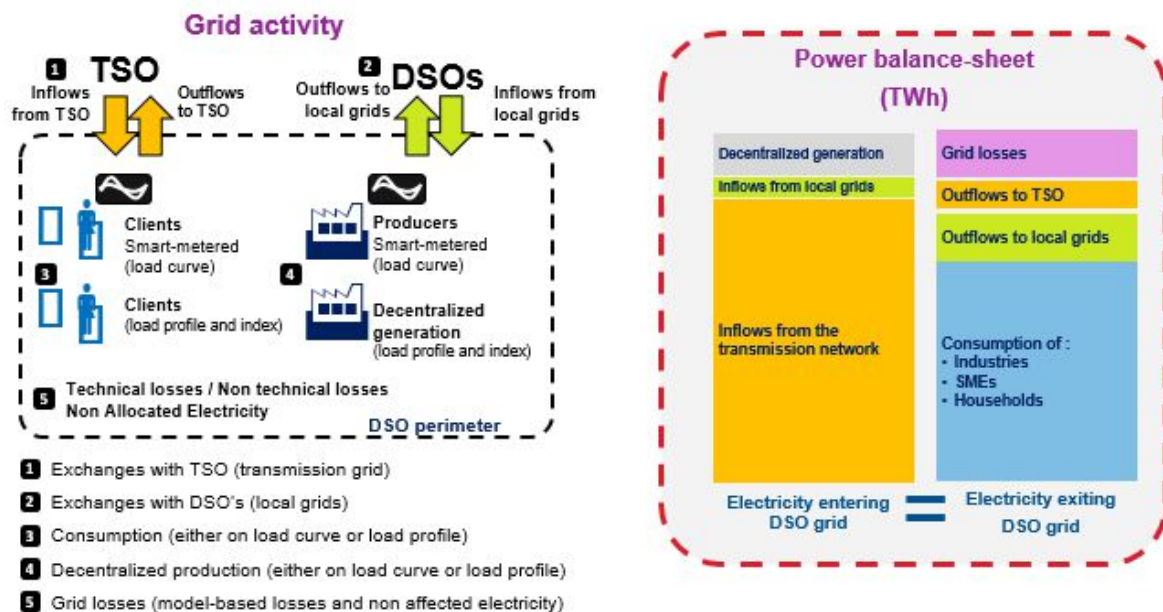

Figure 1: DSO energy balance reflects physical flows on DSO grid

Concrete application

The practical losses are directly calculated from the relevant energy balance, either financial (with a global difference between accounting volumes) or physical with some network measurements.

Globally speaking, the energy settlement process makes the comparison between global network measurements energies and global customer billed energies :

Definition	Calculation
ENTERING ENERGIES = All the electrical flows entering the network	Raw network measurements, or – if available – contracted energies between TSO and DSO (or between 2 DSOs)
EXITING ENERGIES = All the electrical flows exiting the network for consumption purposes	The energies shall be properly accounted either with raw measurements or with billed energies, including energy estimations (missing values, non-metered flows, ...)
GLOBAL LOSSES	Following this definition, losses can constitute a specific energy balance sheet in settlement process, with all energies non-attributed to any actor.

Table 6: Detail of calculation steps for global losses

Nota-Bene :

- The conventional energy balance rules will have to conform as closely as possible to the given definition of physical losses (for example, in the way consumption without contract should be considered as losses).
- The applied rules can be very simple or - on the contrary - complex and adapted to each type of flows, according to the data accuracy and to the final goals of losses calculation (economic estimation of losses, and market rules for losses purchase among others).

Calculation period

The reference period for losses calculation is very important:

- Losses have to be at least calculated on a one year period, because of their seasonal dependence (climate effect, seasonality of consumption or also produced energy).
- It is also better to estimate them as an average value over 2 or 3 years to control for external effects like climate.
- Where available data and processes make it possible, more frequent calculations (e.g., monthly) may lead to a better understanding and forecast of losses.

Calculation network area

The reference network area for energy balance is also important:

- Entering energies will have to be correctly determined, either with network measurement or estimation (e.g. rules to estimate energy in feeders from measurements made at substations): if an energy is not correctly measured at the frontier between two networks (DSO or TSO), both networks energy balances will be affected and will lead to inaccuracies in loss calculation / estimation.

- Where available data and processes make it possible, more local calculations (e.g., for each regional unit of a DSO) may contribute to a better knowledge of losses repartition and help mitigation actions.

Smart meter impact

In case of conventional meters, the energy considered in energy balance is not an exact measurement, but is interpolated or in any case elaborated. The first benefit of smart meters is an improvement of measurement accuracy and frequency, especially with a synchronism of all energies on an exact measurement period (eg. an annual period will be measured from 00:00.00 of January 1st until 23:59.59 of December 31st).

Moreover, smart meters also allow a cost reduction of the measurement operational process:

- they shall be used the same way for entering and outing energies, especially for network measurement, as part of a global smart-grid strategy
- they will allow more precise energy balance on short periods and on smaller areas, and help control actions (Cf. 2.2.3)
- Some estimation methods are experienced to ameliorate losses measurement from a partial SM roll-out with a sample of smart meters and some adapted profiling methods [REE 2015] and [Enedis 2013]

3.2.2. Measurement of TL-NTL detail (Level 2)

General Principle

The definition in the previous part of this report proposes to split the global losses into technical and non-technical losses.

The measurement method reflects this definition, with a 2-step calculation :

- Step 1 = evaluation of Technical Losses by a specific physical model
- Step 2 = calculation of Non Technical Losses by difference between Global Losses (Level 1 definition) and Technical Losses (Cf. Step 1)

Concrete application

Technical Losses evaluation

Without possibility of a “real measurement” of technical losses, which would need perfect measurement of the energy flows in all network components, it is necessary to use some electrical models to estimate them:

- Electrical models applied to estimated flows inside the real structure of the network can reflect the reality of both consumption and embedded generation.
- The losses characteristics of network components (e.g. iron loss for a specific type of sub-station) can be validated through laboratory tests and simulations.
- The measurement of losses applied on some sample network components in real conditions can provide an indication of the level of losses and can be extrapolated to the whole network (or used to validate the estimation of losses).

- The evolution of global losses may be compared with that of the network (more lines or components lead to higher losses) and with that of energy flows (losses used to be linked to consumption, but local generation has also an impact on losses level).

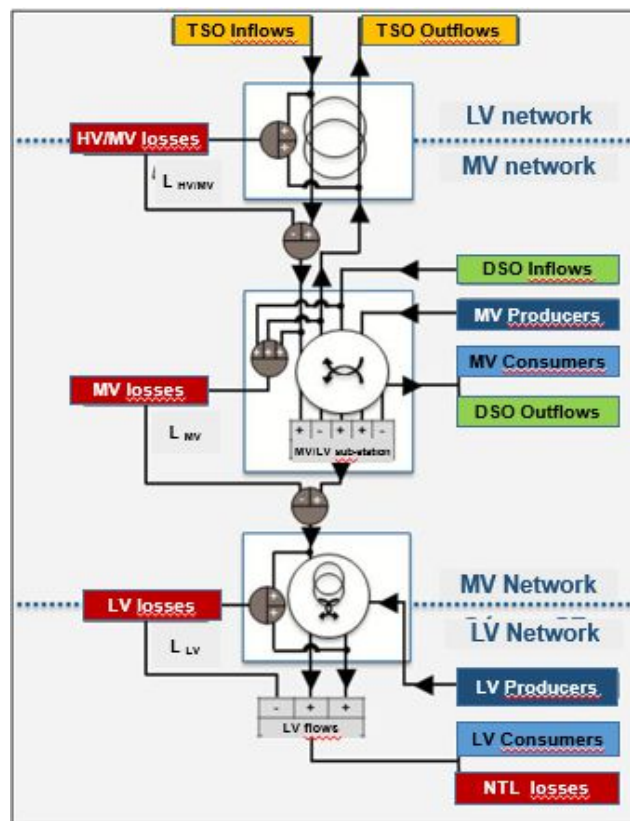

Figure 2: Example of MV and LV technical losses models (courtesy Enedis)

Nota-bene : besides energy losses calculation over a period, losses at peak power may also be calculated for network planning purposes in the following ways:

- through estimated peak load factors applied to the energy losses
- with a global load-curve measurement for network (or sum of connected clients) and a model for losses

Non-Technical Losses calculation

Non-technical losses are calculated as the difference between :

- Global Losses (calculation from Level 1 definition) and
- Technical Losses (estimation in Step 1)

This necessitates coherency between different calculations :

- spatial coherency : global losses calculation and TL estimation will have to be done on the same network area
- temporal coherency : both for the global period and the calculation steps (yearly, monthly, or even daily in a smart-meter context)
- other calculation parameters will also have to be adjusted, depending on, for instance, whether the calculation refers to real or normalized climatic conditions

More globally, the split between TL and NTL is a way to precise the global energy balance considered for the level 1 definition.

Nota-bene :

- Estimated non-technical losses may include some uncertainties arising out of the evaluation of technical losses.
- The actual level of NTL can be confirmed through a comparison with the detailed NTL by origin (Cf. 2.2.3).

Smart meter impact

Smart meters are a key factor to improve TL models for the calculation of losses:

- They offer better measurement accuracy of the LV network load, deducted from the customer meters' aggregate load (both for energy losses and peak power losses modeling)
- They offer the opportunity to verify and correct network connection information (attached sub-station, phase, ...) when allowed by the AMI data communication (e.g. with PLC system which reflects electric flows)

3.2.3. Measurement of losses factors (Level 3)

General Principle

The 3rd definition refers to the factors, that explains the global level of both technical and non-technical losses. It represents a non-exhaustive list that may follow the evolution of distribution network activities:

- On technical losses : new low loss materials, DG impact on losses, Etc.
- On non-technical losses : "smart" processes, NTL mitigation activity, ...

Consequently, the sum of all identified measurement factors cannot totally fit to the global losses measurement obtained by the other definition (levels 2 and 3) and it is necessary to standardize these different definitions.

Concrete application

The main factors for non-technical losses can often be ascertained through an analysis of DSO processes. However, it is much more difficult to evaluate the level of each factor of losses factor.

Two different approaches may help sharing energies according to this "losses factors" definition:

1. A "by-difference" approach with a part of energy losses energy that would remain unassigned (or assigned to a "undefined / other" sector)
2. An "homothetic" approach with a sharing of global losses energy in proportion of the "identified factors" energies

Practically, the preferable approach depends on the type of losses (TL or NTL).

Technical-losses

As TL models rely on the physical representation of the network, it is generally possible to consider “sub-models” that concern “sub-networks”:

- relative to a physical area (e.g. a DSO operational sub-unit)
- relative to a network voltage level: MV and LV, with difference between lines and transformers for each voltage level
- comparing the individual network component characteristics with expected load for the network component (with load flow models)

In this case, it is natural to choose an homothetic approach, coherent with the technical losses model : global technical losses for a network are equal to the sum (or weighted sum) of all TL for all the network components.

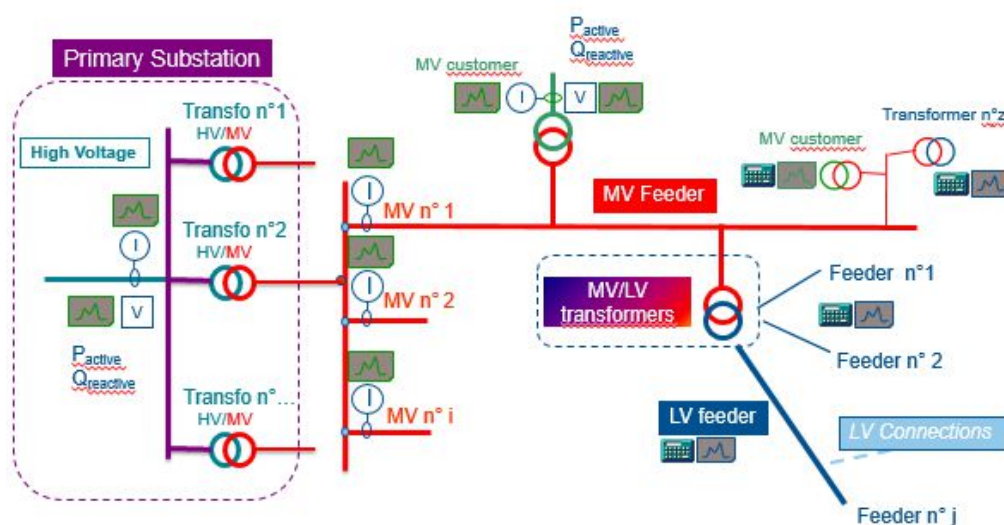

Figure 3: View of a network as the sum of its network components

Non-technical-losses

As previously mentioned, an analysis of the DSO processes can help identify the factors contributing to NTL. However, it is harder to quantify them, because:

- Detected issues provide rich information on NTL factors, but do not always reflect the reality of level (?) of losses
- Some NTL factors are easier to evaluate than others :
 - o The NTL level may be quite well known when an energy flow is measured but not correctly assigned to a customer, (e.g. with energy consumed during move in – move out process)
 - o The NTL level may be estimated by statistical methods (e.g. with metrologic controls to quantified the energy relative to meter malfunctions)
 - o In other cases, the detected cases give a partial, and even sometimes biased view of the potential levels of NTL (e.g., with some illegal connections or meter bypass that can hardly be detected by on-field teams)

Consequently, it is often necessary to consider a “by-difference” approach, with an “undetermined NTL” category to obtain a coherency between the sum of determined factors and the global NTL levels.

KPIs for TL and NTL

In order to take into account the difficulty to have a global view on the different factors that constitute NTL factors, it is possible to define relevant KPI on detected cases and on some “risk factors” for the different operational areas of a DSO (e.g. move in – move out frequency) in order to:

- Evaluate mitigation methods efficiency (hit ratio on successful cases).
- Estimate remaining losses level (number of new cases, hit ratio on non-successful cases).
- Allow a possible comparison with the evolution of global losses (if possible, on a restricted period or area) and ascertain if mitigating the factors contributing to losses factor results in a reduction of global losses.

TYPOLOGY	DESCRIPTION	Detected volumes
Frauds	<ul style="list-style-type: none"> Metering tampering by customer Direct connection / By-pass Illegal re-connection 	X %
Defects of metering	<ul style="list-style-type: none"> Defective meter Tariff relay defect 	X %
Customers without contracts	<ul style="list-style-type: none"> Energy delivery without meter Unknown delivery point in customer database Consumption for customers supposedly disconnected 	X %
Tariff errors	<ul style="list-style-type: none"> Error on tariff Error in the contract setting Difference between files setting and metering settings (CT) 	X %
Consumption non invoiced	<ul style="list-style-type: none"> Generation TSO secure feeding DSO secure feeding 	X %

Figure 4: example of typology with NTL key factors (courtesy Enedis)

A global strategy (often called “revenue assurance”) can be setup to secure DSO operational processes and mitigate NTL, as recently illustrated by EDP, with :

- an action plan based on four pillars - Organization, Processes, Procedures and Systems - consisting of defined actions across the entire process and measurement through relevant KPIs
- a holistic approach to the revenue value chain (meter-to-cash process), from the operational field teams, through legal and data analysts, to information systems.
- a trend for data accrued by telemeter devices and smart-meters, helping in a more precise identification of opportunities for losses reduction.

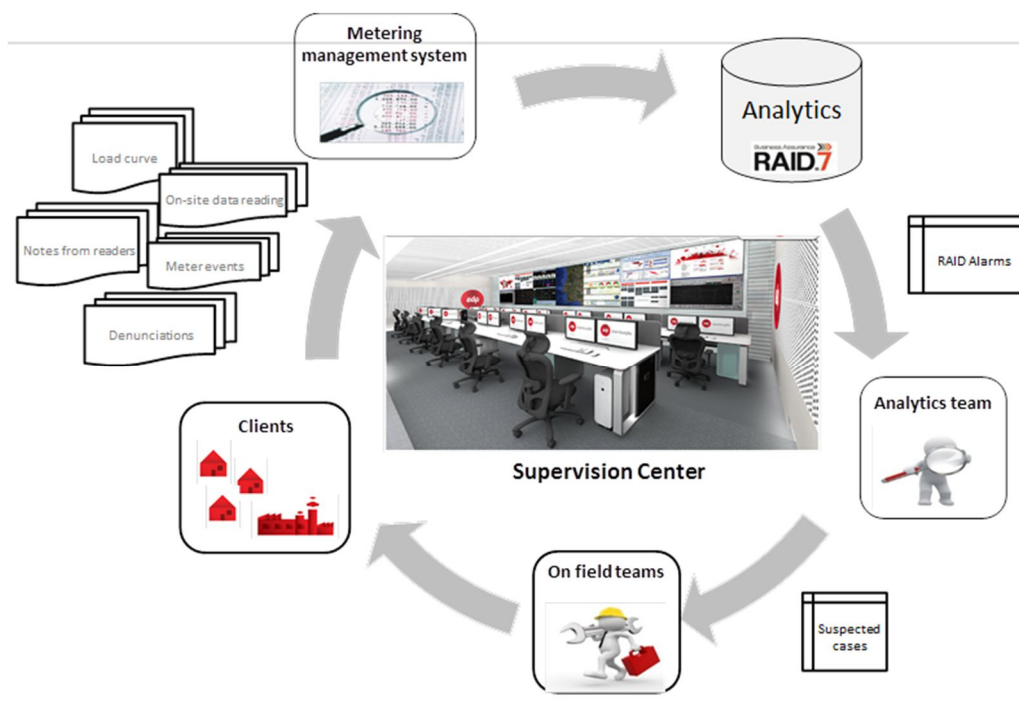

Figure 5: example of “revenue assurance” operational strategy based on KPI analyses (courtesy EDP)

It is also important to consider the way losses (both global, TL and NTL) are expressed:

- **Raw levels of losses** in kWh are of significance for the DSO, but a direct comparison with other DSO losses levels is more difficult: indeed, DSO losses depend not only on the network structure, but also on network energy flows.
- **Losses rates** make a comparison between loss and energy flow levels. Consequently, they provide reference values that may be rather comparable between networks, even if they are detailed by voltage level for relevant benchmarks.
- Raw losses values and losses rates will have to be **calculated over long periods (at least 3 years)** to ensure stability and robustness, as a losses for a given year may not be significant due the variability and uncertainty (data collection hazards, climatic conditions, ...)

Smart meter impact

Smart-meters can impact loss KPIs in two ways:

- **“Smart” process:** improving and securing DSO process, especially on measurements and contract information on the “meter to bill chain” (e.g. IT integrity with a unique value for a data in all IT systems).
- **Data mining:** tracking and classifying anomalies, with an ever greater telemetered data usage in analysing TL and NTL, and with the help of big data algorithms. In this case, KPIs are constituted by lists of potential anomalies and are associated a “hit-ratio” relative to their detection.

3.2.4. Complementary losses measurements (Levels 1 - 2 - 3)

These different measurement methods prove to be compatible and even complementary, with the possibility of combining them. This allows for a more precise focus on losses, giving some information on the main factors for losses. This can then help find the best way to control them.



	Level 1 : Global losses	Level 2 : TL / NTL detail	Level 3 : Detailed losses factors
Objective / losses	Measure 	Manage 	Mitigate 
Method	Energy balance	TL model (global) + Energy balance (level 1)	TL model (analytic) KPI & analyses on NTL
Example	Potential volumes for losses mitigation actions	DG impact on TL Progress of NTL mitigation action plan	Location, qualification and prioritization of NTL volumes
Smart-meter impact	Energy measurement (network & customer)	Energy measurement Connection corrections (GIS)	"Smart" process Datamining
Period	Annually (+ monthly)	Annually	Monthly
Geography	DSO & Sub-unit (physical perimeter)	DSO & Sub-unit (local TL model)	DSO & Sub-unit (NTL sources identification)

Table 7: Characteristics of measurement methods for each definition of losses

Nota-bene : the different loss measurement methods give reference levels for a network. They may be characteristics of the network structure and - under certain conditions - of its efficiency. The difficulty to compare losses will be detailed in the parts of the report that follow, both on TL and NTL.

3.3. CONCLUSION

The effectiveness of the definition of losses can be confirmed by the main findings in the measurement methods for losses:

1/ Specific and practical measurement methods can be elaborated for the three different definitions that have been proposed by the Working Group:

- Global losses estimation (Level 1) : energy balance
- Technical / Non-technical losses repartition (Level 2) : technical losses model
- Detailed losses by origin (Level 3) : KPIs & analyses

2/ These different measurement methods prove to be compatible and even complementary, with the possibility of combining them. This allows for a more precise focus on losses, giving some information on the main factors for losses. This can then help find the best way to control them.

3/ Smart meters have an important impact on the measurement of losses for the 3 defined losses levels :

- Facilitating and improving the energy measurement, both for final customers / producers and for network equipment, including higher precision in
 - o Temporal and geographic energy balances
 - o Temporal and geographic technical loss models
- Helping in the limitation of network and process uncertainties and anomalies
 - o Connection corrections in GIS (if adapted AMI communication systems exist)
 - o Data mining methods for anomaly identification and quantification

Through rigorous and virtuous approaches, measurement methods may be considered as one important basis of a global smart-grid approach.

4. TECHNICAL LOSSES

4.1. INTRODUCTION

4.1.1. TL definition (reminder)

As developed in Definition part, technical energy losses in electricity networks are summarized in Figure 1.

Fixed	Corona losses Leakage current losses Dielectric losses Iron losses / No load losses
Variable	Joule losses Copper losses / Load losses Losses caused by contact resistance Consumption in protection systems
Network services	Losses caused by continuous load of measuring elements Losses caused by continuous load of control elements

Figure 1: Summary of technical losses types

4.1.2. Objectives of the TL section

In the previous section of this report, a formal definition of the different types of distribution network losses and the components that constitute these losses were outlined. In this part of the report, we look closer into technical losses, their size, and steps towards their mitigation in distribution networks.

We remind the reader of the following concepts to be kept in mind for easy understanding of this portion of the report:

- As explained, the total losses in any network consist of technical losses (TL) and non-technical losses (NTL).
- The total losses in a network are defined as the difference between the overall input energy to the network and the overall energy consumption in the network.
- A separate metering of TL is not possible in networks, especially in low voltage (LV) networks, where NTL tends to be especially high. More information on this follows in the next part of the report on NTL.

The calculation/estimation of TL using detailed information of the network under consideration is possible. The information available for various networks depends on the voltage levels (with more information generally available for higher voltage networks) and in the country (more, specific information is generally available in developed countries).

There are several reasons one may want to reduce the TL. Often, it could be because distribution system operators want to decrease expenditures on their networks. It could also be due to the political framework and regulation in countries for incentivizes the reduction of TL. We can cite for example the 2012 EU Energy Efficiency Directive that established a set of binding measures with respect to energy efficiency. The requirements outlined in the directive include among others, a 20% increase in energy efficiency by 2020 across the entire value chain. More recently, the 2016 “Winter Energy Package,” first proposed by the EU on the 30th of November 2016, includes a stricter 30% target, along with measures to ensure the new target is met [1][2].

4.2. TL SIZE IN DISTRIBUTION

4.2.1. Global view

A lot of information is generally available with respect to the level of losses. However, in order to compare losses, one has to take into account the following:

- What does loss ratio mean? (Only technical losses or total losses?)
- What is the base (100%) of the energy? (Input energy or consumption?)
- Is transit energy included? (eg, energy from transmission to distribution network through another distribution network)
- Which type of network is considered? (Only distribution, transmission and distribution together?)
- What types of voltage levels are analyzed? (not all Distribution System Operators (DSOs) have high voltage)

Some respondents are of the opinion that separating the contributions of technical and non-technical losses is a difficult task [3]. Thus, comparisons of losses in the world are generally based on total losses (and not directly on TL, that are always lower), as shown in following examples.

The figures below (Figure 2 to Figure 6) present the evolution of losses level in transmission and distribution systems across the world. This data was sourced from The World Bank [4].

Figure 2 shows the evolution of losses worldwide over the years 1993-2013 as a percentage of the total energy transported and distributed in electrical power systems.

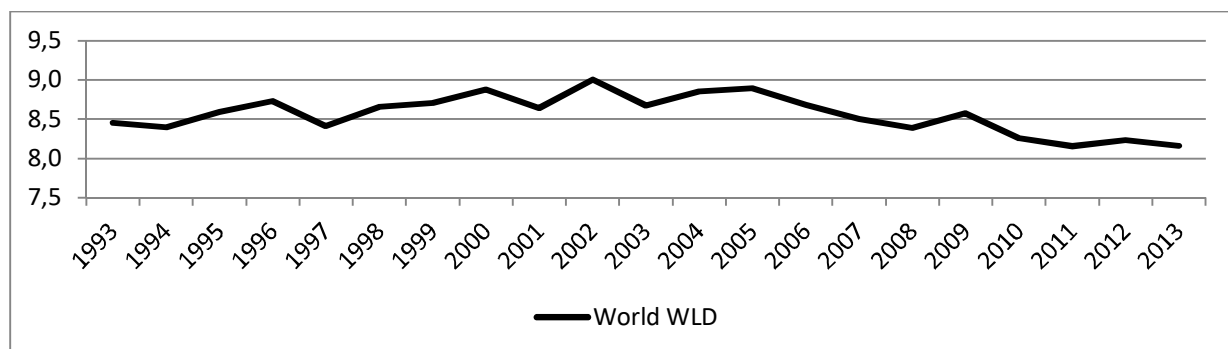

Figure 2: Total Losses 1993-2013 World (% of output)

The world average is slightly above 8% of the total electrical energy consumption in 2013. Although the trend of losses is shown to decrease across the world in general, it is possible to find examples to the contrary in certain countries or continents.

Figure 3 shows the evolution of total losses for the same period in the Americas, while Figure 4 shows the evolution of losses in three representative countries in Europe.

Similar illustrations for the evolution of losses in Asia and Africa can be found in Figure 5 and Figure 6 respectively.

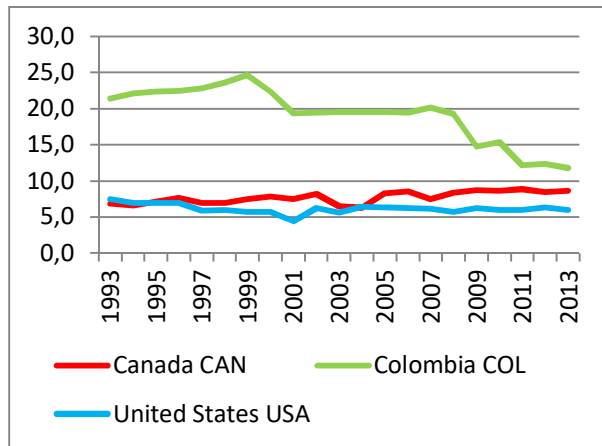

Figure 3: Total Losses 1993-2013 America (% of output)

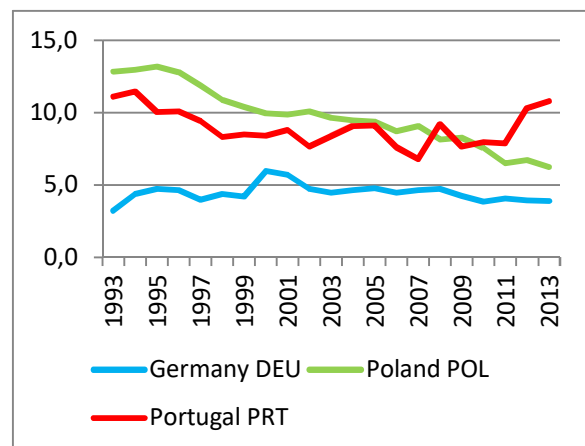

Figure 4: Total Losses 1993-2013 Europe (% of output)

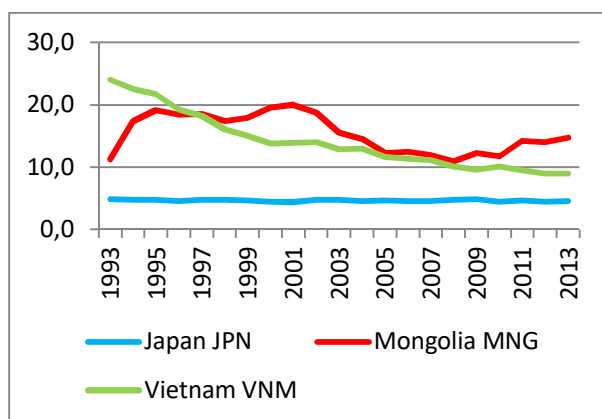

Figure 5: Total Losses 1993-2013 Asia (% of output)

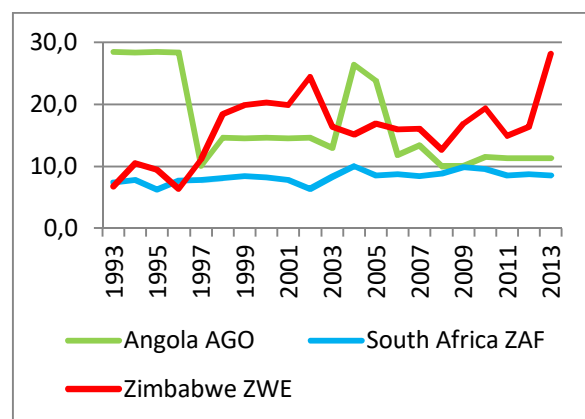

Figure 6: Total Losses 1993-2013 Africa (% of output)

The trends in losses in developed countries, where losses are generally low, are shown to be more or less stable over the given period. The biggest decreases, and sometimes the biggest increases, are shown to occur in developing countries, like Colombia and Zimbabwe respectively.

4.2.2. Detailed view on TL

French and Northern Germany distribution networks

In France, data about the size of TL in distribution networks is available from the largest distribution system operator Enedis (originally ERDF) [5]. The TL shown are estimated from manufacturer datasheets, iron losses in transformers and conductors, and statistical calculations which consider load curves. In 2006, Enedis is shown to register a TL of 12 TWh.

The injected power in the network was about 354 TWh, which translates to a loss percentage of around 3.4%. Figure 7 shows data from France and similar detail information from a specific small part of Germany.

Grid levels	Northern Germany	France
HV/MV substations	10%	17%
MV grid level	34%	28%
MV/LV substations	14%	36%
LV grid level (lines, connections, ...)	42%	19%

Figure 7: TL % in the French and specific small part of Northern Germany distribution networks [5] [9]

These separate figures, primarily reflecting strong context differences, can be used for detailed benchmarking and the allocation of efficiency efforts. Such differences emphasize the importance of an individually and detailed analysis as basis for grid planning [9].

GB rural and urban distribution networks

Great Britain example illustrates that TLs are strongly linked to the type of grids: see Figure 8.

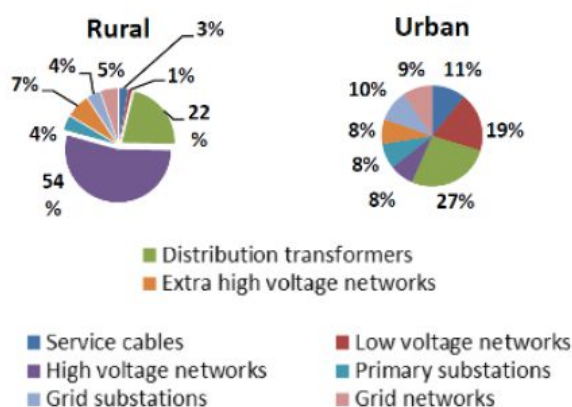

[Chart: nature of losses in different types of networks](#)

Figure 8: TL % in rural and urban distribution networks in Great Britain [21]

It appears in this example that on rural network, the majority of losses occur on the high voltage part, whereas on urban network losses occur mostly in distribution transformers and on the low voltage part.

In most cases, the DSOs' priority is the quality of services, taking into account the quality/cost ratio. Once the network is strongly established, losses optimization becomes more relevant. However, losses may deeply vary depending on the network type. Moreover, determining a reference level of losses for a network is a complicated question: Would a unique regulation for all types of network on the national territory be efficient?

Energy of TL in urban distribution networks in developed countries can be about 3,5% of the energy delivered in these networks, but TL in rural networks may be up to twice as much higher due to delivery of energy to larger less populated areas. It is difficult however, to pinpoint the exact levels of TL in networks worldwide, as they are dependent on the type and age of the

equipment in the network, the amount and load profile of the distributed energy etc. This is also one of the reasons why various studies give different results for losses level.

4.2.3. DSO concern on TL

The presentation of WG survey results gives the aggregate answers of the DSO and proposes a focus on some specific issues (Table 1).

Technical Losses	Europe								
	Sweden	Austria	Slovenia	Czech	France	Italy	Portugal	Spain	UK
Fixed Component	H	H	H	H	H	H	M	M	M
Variable Component	H	H	H	H	H	H	H	H	M

Technical Losses	Asia			America	
	Japan	China	Indonesia	USA	BRAZIL
Fixed Component	H	H	M	M	M
Variable Component	L	M	L	H	H

Table 1: Survey - Qualitative ranking of countries with respect to TL components
(LOW/MEDIUM/HIGH)

As far as losses are concerned, all countries consider that TL are a high concern, with some difference between the fix component (network investments) and the variable component (energy efficiency, regulation on TL volumes).

4.3. METHODS FOR TL MITIGATION

TL can be mitigated in several ways. Fixed losses, like the core losses in transformers, can for example be reduced by using more efficient transformers. However, they cannot be eradicated. The literature indicates that variable losses contribute more than fixed losses to the total amount of power system TL. This also means that most of the efforts in reduction of TL concentrate on the reduction of variable losses. In this section, we outline some of the important measures that can be taken to mitigate TL.

4.3.1. Component Replacement

Increasing voltage level

Increasing the voltage level in distribution networks reduces the currents required to distribute the same amount of power, increases current capacity of the grid and reduces substantial voltage drops and line losses [7]. However, care must be taken during the implementation of this solution, as insulation damage may occur more easily with increased voltages.

Eliminating transformation steps

Fixed losses can be reduced without replacing equipment by reducing the number of energized transformers in the system. This can be achieved by eliminating transformation steps which could be achieved by direct coupling of higher voltage levels to lower ones without the use of intermediate transformers (use of a single transformation step).

Increasing line capacity

Increasing cross-sectional area of cables leads to reduction of variable losses. This is due to the fact that conductors with higher cross-sectional area have lesser resistance. An alternative approach is to make use of high-temperature superconductors (HTS) which have infinitesimal resistances when they are cooled down at -180°C and can carry five times the current of a conventional cable system with the same outer dimensions. The only losses in such systems are due to the energy needed to operate the cooling mechanism [7].

Figure 9 illustrates one of possible examples for 400V cable.

Input parameters		Electrical loss and emission for different conductor sizes							
Max Load current, A	50.3	Size, mm^2	R, $\text{m}\Omega$	Ducted Rating, A	Utilisation ($I_{\text{peak}} / I_{\text{rated}}$)	Loss @ peak load, kW	Annual E Loss, MWh	Annual tCO_2 emiss.	40 Yrs tCO_2 emiss.
Loss Load Factor	0.25	95	96	201	0.25	0.73	1.59	0.86	34.2
Length cable, km	0.3	185	49	292	0.17	0.37	0.82	0.44	17.5
Lifetime, Years	40	300	30	382	0.13	0.23	0.50	0.27	10.7

Figure 9: Electrical losses for different cross-sectional area of 400V cable [6]

More generally, a DSO has to choose the right cross section on a long term techno-economic optimization which balances losses savings and current capacity over equipment over-costs of a higher cross section.

Energy efficient transformers

As transformers are responsible for both variable and fixed losses in the system and their replacement is easier than changing cables or lines, this option presents a good loss reduction potential, and affects almost all factors of losses. The asset replacement strategy depends on the state of the population, characterized by the age, size and type of transformers. The lifetime of transformers is typically around 40 years, meaning that efficient transformers can have a long-lasting impact on the TL in the network [7].

In paper [21] from year 2014, it is possible to find interesting analysis about costs for different least-cost distribution transformers. Figure 10 shows the outcome of the analysis of economic network loading of distribution transformers, with losses assessed using discount rate of 3.5% over 45 years. It is interesting to observe that transformer capital costs are similar to the cost of losses and that, in this paper, the optimal utilization of transformers may be between 60% and 100% [21]. This ratio results from a techno-economic approach that may accept lower

values in some cases and that has to consider the complete costs and operational constraints (e.g. the transformers design should also assess contingencies situation, like transformer sizing).

Rating (kVA)	CAPEX (£)	Peak demand (kVA)	Cost of losses (£)			Total cost (£)	Peak Utilisation Factor
			Load losses	No-load losses	Total		
315	13,137	315	9,254	6,984	16,238	29,375	100%
500	14,168		5,249	10,277	15,526	29,694	63%
630	15,020		3,928	12,272	16,200	31,220	50%
500	14,168	500	13,173	10,277	23,450	37,618	100%
630	15,020		9,858	12,272	22,130	37,150	79%
800	15,199		6,373	12,711	19,084	34,283	63%
500	14,168	630	21,066	10,277	31,342	45,510	126%
630	15,020		15,764	12,272	28,036	43,056	100%
800	15,199		10,191	12,711	22,902	38,101	79%

Figure 10: Least-cost Distribution Transformer for case discount rate of 3.5% over 45 years [21]

Transformer losses in the EU electrical network are estimated to be in the range of 70 to 100 TWh at the current load factors. Distribution and power transformers represent around 5 million units. After power lines, distribution transformers have the second highest potential for energy efficiency improvement. Modern transformer technology is capable of reducing transformer losses considerably. More detail is in Appendix - Cut costs, losses with transformer technology upgrades [11].

Losses caused by continuous load of measuring element and control elements

This type of losses is generated due to small own energy consumption of elements. Amount of meters and control components is sizable, so it is not possible to ignore it. Modern electronic meters have consumption lower than electromechanical meters, but probably implementation of smart meter causes consumption growth again, especially with a more solicited communication system. More detail is in Appendix - Own Energy Consumption of Smart Metering Infrastructure and Energy Monitoring Systems. On the other hand, smart-meters give us opportunity for the realization of other measures. Using more efficient equipment can mitigate this type of TL.

Losses caused by contact resistance

Source of losses is in current flowing through connectors of conductors. There are very small resistances, but the amount of connectors is sizable again. In case of loose connections resistance is higher and even it can cause of power outage. The most frequently used methods for detection of these connections is thermography. Using more efficient insulation piercing connectors can mitigate this type of TL – see Figure 11. There are more details in Appendix - IPC contribution to LV network efficiency and reliability.

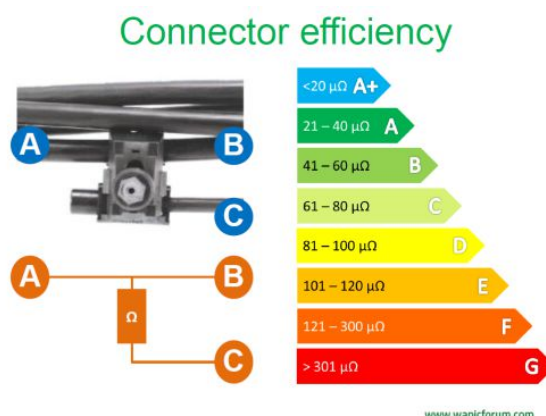

Figure 11: Efficiency scale proposal for LV IPCs [13]

Consumption in protection systems

Amount of protection systems is sizable, so it is not possible to ignore it, much like in case of meters. Source of losses is in current flowing through protection system (effect of “ I^2R ”). Using more efficient protection systems can mitigate this type of TL. More detail is in Appendix - Evaluating Efficiency and Losses of Various Circuit Protective Devices.

4.3.2. Feed-In Control

Feed-In control

This measure refers to applying control actions for local balancing of demand and supply in distribution grids, which leads to reduction of variable losses due to two key factors :

1. the reduction of energy transportation distance (energy is consumed locally).
2. and the reduction of marginal losses (by a flattening of flow profiles) [7].

Role of DG and grid management

Generally, locating generation closer to demand, both in time and space, could reduce losses since the distance over which electricity is transported is shortened and the number of voltage transformation levels is reduced. In reality, such local balancing does not occur. When the penetration of DGs in the network increases beyond a certain limit (see Figure 12), the resulting increase in network flows often translates into reverse flows from distribution networks to

transmission networks [7]. There is an optimum level of DG penetration in every network that can decrease TL.

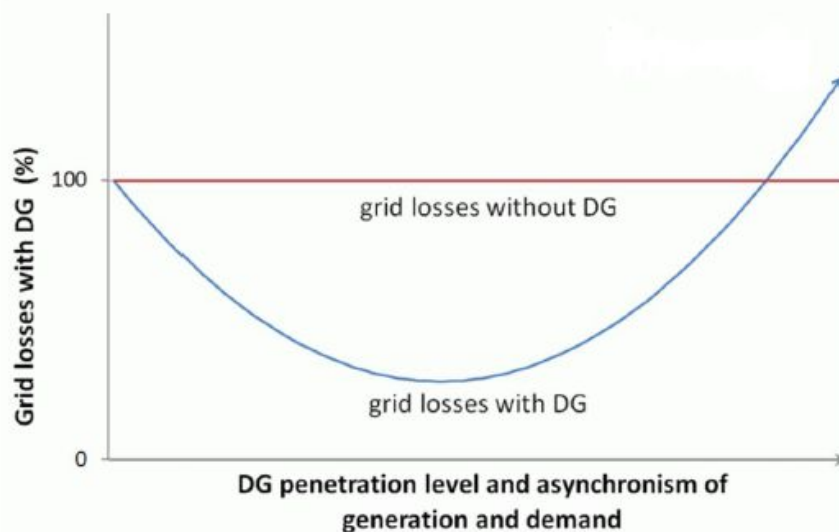

Figure 12: Impact of increasing DG penetration level to grid losses [7]

It is important to keep in mind that this topic was investigated in Spain from the regulatory framework of PV self-consumption installations point of view .

Final results from the paper [16]:

- The selection of the self-consumption regulatory framework has an important impact on energy losses.
- In case of instantaneous self-consumption (self-consumption installation is designed to provide 40% of the annual energy demand of the prosumer) increasing adoption level has mainly positive effect.
- In order to minimize negative impacts, it is desirable to avoid or minimize energy exports from PV self-consumption installations.
- Demand side management or distributed energy storage could allow a better integration of such type of installations.
- Future work may include the influence of geographic dispersion or concentration of PV self-consumption installations [16]

These results are very specific to the context of this analysis investigated in Spain, but they confirm two key factors :

1. The high dependency on Consumption – Generation synchronism (cooling A-C system / PV Generators): they would be quite different with other Consumption behaviours (e.g. with water-heaters or electric car with power peaks mostly during night-time) and have to take into account seasonal and daily variability of PV, as illustrated in Italy [24]
2. The necessary search of new optimized solution adapted to DG new situation, with a comparison between regulatory frameworks adapted to sizing of photovoltaic (PV) self-consumption installations. Another possibility is to consider specific TOU tariffs adapted to actual grid situation [23] and DG local constraints.

More details is in Appendix - Assessing the impact of photovoltaic self-consumption support policies on energy losses

The newest information [17] from this area has confirmed mentioned results and gives further enclosures:

- The replacement of centralized generation by distributed generation may reduce the losses, however, a subsequent increase in losses appears when the adoption levels are increased.
- Voltage control by inverters connected to the MV network is an effective operation measure to minimize over voltages and to operate the network within the voltage limits. However, voltage control by the absorption of reactive power increases losses in all analyzed scenarios. Smart solutions [19] can mitigate this drawback.
- DG coming from PV self-consumption does not always reduce losses. In certain cases losses can increase with respect to initial levels.
- Some kind of incentive policies would lead to serious problems in the networks under high adoption scenarios: losses increase and voltages exceed safety levels. Network reinforcement is necessary to integrate high levels of generation [17]. It generates more costs.

Intelligent management principles adopted by DSOs could also contribute effectively to a decrease in TL. This involves proactive steps taken by DSOs to manage their distribution networks. At the European level, a lot of research projects have in recent times focused on this issue. The evolvDSO project <http://www.evolvdso.eu/> is one of such projects that focuses on the evolving roles of DSOs in active distribution network management, and has created tools that help DSOs manage, among other things, variable TL in their networks.

Another important European research project is <http://www.grid4eu.eu/> GRID4EU (Large-Scale Demonstration of Advanced Smart Grid Solutions with Wide Replication and Scalability Potential for EUROPE). The project aimed at testing innovative concepts and technologies in real-size environments. It focused on how DSOs can dynamically manage electricity supply, demand and to reduce energy losses [18]. One of the main results of the final report GRID 4EU – Automation at LV and MV levels also open up further levers to decrease energy losses.

DSOs have obligation to connect increasing penetration of DGs (renewable). The Economic potential of solutions depends on implementation costs and on regulation framework. In paper [19] two solutions (self-adaptive reactive power control and active power curtailment) on MV networks are considered with aim to show profit of cost-benefit analysis. More details is in Appendix - Cost benefit analysis of MV reactive power management and active power curtailment

More globally, the global DG impact on losses (reduction vs increment) depends both on geographic proximity and time synchronism between DG and other network flows.

Reduction of marginal losses (Load smoothing)

A study of the effect of load profiles on the variable TL shows that smoother load profiles lead to lower variable losses in the system. We refer to Figure 13, where two different types of load curves have been tested on a system and compared with its base load curve [7]. The smoothed load curve (in blue) shows a reasonable amount of reduction in these losses, while the average load curve (in green) shows a large reduction in the same.

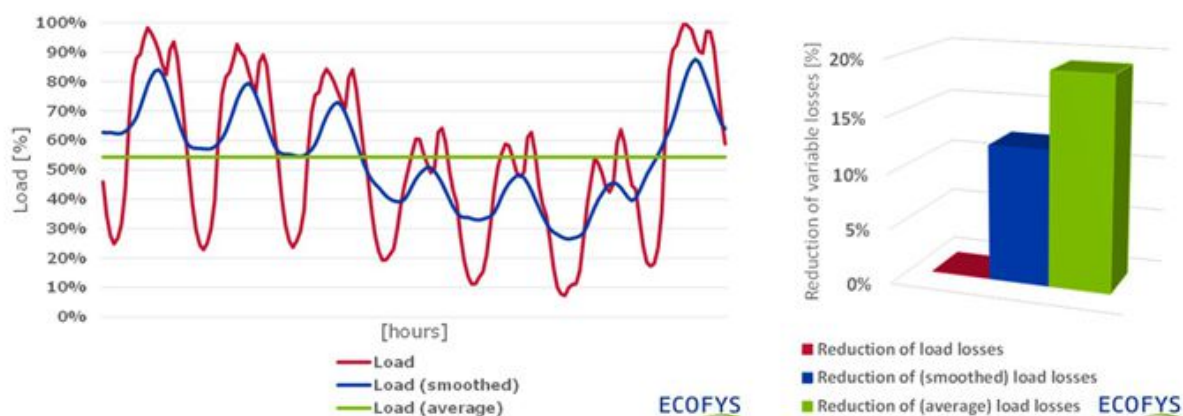

Figure 13: Impact of smoothing the system loading on the reduction of variable losses [7]

In all cases, the same energy is carried by the system. But the loading profiles present a different variability. Smoother loading profiles lead to significant losses reduction, up to 20% for a flat profile [7].

4.3.3. Grid Management

Transformers switching

Alternatively to elimination of transformation steps which would be a long term action, a grid management solution as switching off transformers could be possible in periods of low demand for configurations where multiple transformers are required in a substation to meet peak load or for redundancy [7].

Network reconfiguration

The configuration of the network has an effect on losses in terms of the distance the electricity is transported. MV networks are typically configured as open loops and are controlled in order to be able to isolate faults and restore power. As the demand changes spatially and in time, it is often the case that the configuration of a network is not the optimal one for the specific demand situation. There might therefore be some scope for reducing losses by reconfiguring the network, to provide shorter, more direct paths to where highest demand is situated [7].

Reactive power management

Local voltage control actions (reactive power injection or absorption) are the most widely accepted means for supporting voltages and reducing reactive losses in distribution networks. This reactive power compensation can be brought by capacitor banks placed in the networks [7], or through the compensation of distributed generation connected to the network.

Further information about “2/3 rule” for sizing and placing capacitors is in Appendix - Using capacitors.

Imbalances

Imbalances in the loading between the three phases lead unavoidably to increased currents in at least one phase, which increase marginal losses. Imbalances are a common phenomenon in LV networks where single-phase or double-phase customers are connected to the three-phase system. These imbalances lead to having one phase carrying higher currents, giving rise to variable losses. The measure is to statically or dynamically transfer loads from one feeder to another to balance the total load across multiple feeders and transformers. As the demand changes in time, optimally balancing should be performed in short time periods and reacting to demand changes [7].

This topic was investigated in France in context of smart grid data with the aim to develop new calculation tool for LV networks design based on AMM data, individual load curves and real phase connections. Final results from the paper [20].

Large Scale Diagnostic

Dashboards generated by developed system turned out to be very useful to detect LV grids having constraints or being close to constraints: overloaded transformers and feeders with excessive voltage drops. In most cases, phase-unbalance is responsible of these drops.

Approximately, 50% of LV feeders can benefit from phase balancing, meaning that their performance (losses, quality) can be improved thanks to few smart phase switching. However, only a small proportion of these operations are profitable, less than 10%, since balancing costs (OPEX) can be high in some cases, especially in urban areas [20].

Phase-Balancing Study Case

This load-balancing operation substantially improves grid's performances. Voltage constraints are eliminated and power flows are much better balanced. More details are in Appendix - First use of smart grid data in distribution network planning [20].

4.3.4. Qualification of TL Mitigation Methods

One recent study [7] has classified possible methods for reducing TL according to their potential impact on losses – see Figure 14:

			Applicability		Effectiveness		
			Distribution Networks		Technical Losses		
					Variable		Fixed
			LV	MV	Marginal	Reactive	
Component Replacement	Energy Efficient Transformers		XXX	XXX	XX		XXX
	Increase Line Cap.	Increase Diameter	X	X	XXX	XX	
		HTS		X	XXX	XX	
	Increase Voltage Level			X	XXX	XXX	
Feed-in Control	DG	VRES	XX	XX	X		
		Control (M-CHP)	XX	XX	XX		
	Energy Storage		X	X	XXX		
Grid Management	Network Mgmt.	Transformer Switching	XX	XX	X	X	XXX
		Network Reconfiguration		XX	XX	XX	
	CVR		X	X	XX		
	Voltage Optim.	Reactive Compensation Devices	XX	XX		XX	
		Smart Transformers		XX		XXX	
		DER Voltage Control	XX	XX		XXX	
Balancing 3ph Loading		XXX		XX			

Figure 14: Mapping of the energy efficiency potential of each measure [7]

CHP - Combined Heat and Power

DR - Demand Response

DG - Distributed Generation

VRES - Variable Renewable Energy Sources

CVR – Conservation Voltage Reduction

DER – Distributed Energy Resources

EE – Energy Efficiency

HTS – High Temperature Superconductors

4.4. STRATEGIES FOR REDUCING TL

4.4.1. DSO use of TL mitigation methods (WG survey)

The survey performed for the CIRED WG reports DSO opinion about several mitigation methods, including new technologies, according to their potential impact on TL.

Components methods

DSOs generally use techno-economic approach including losses in cost-benefit analysis (Table 2).

Question	Yes	No
Have you made a cost-benefit analysis (CBA) for the investment and loss reduction over the lifetime of your components?	13	3

Table 2: Survey question on cost-benefits-analysis

DSO are questioned about the most interesting solutions emerging, available to tackle losses (Table 3). Low loss transformers and - at a lower level - low loss connectors represent the most promising solutions, whereas superconductors are hardly not considered.

	Solution	High	Medium	Low
Component	Low Loss Transformers	12	2	0
	Connectors	3	8	2
	Superconductors	0	2	7

Table 3: Survey question on emerging component technologies

Feed-in-control methods

Reactive Power, and DER (Distributed Energy Resources) like Distributed Generation, Demand Response etc., may have some positive or negative impact on losses (Table 4).

A majority of DSOs see some opportunities for loss reduction through the use of flexibilities and have started to analyse their impact on losses. Thus, only few of them have started discussions with regulation bodies and upstream / downstream stakeholders on the subject (some in southern Europ, with much PV and relatively high losses, ... and some in Northern Europ with little PV and low losses !). Last point, no compensation is currently planned for potential negative impact of DER on losses except by one DSO in Brazil.

Question	Yes	No
Have you started to analyse their impact on your losses?	12	6
If losses increase due to external control of DER, is there any compensation planned for such a potential negative impact?	1	13
Do you see some opportunities for loss reduction through the use of flexibilities?	14	3
Have you started discussions with regulation bodies and upstream / downstream stakeholders in order to organize / optimize the use of these flexibilities, especially with respect to losses?	4	14

Table 4: Survey question on Feed-in-control

Besides, a minority of DSOs consider storage as an interesting emerging solutions, available to tackle losses, by (Table 5).

	Solution	High	Medium	Low
Feed-in Control	Storage	1	3	10

Table 5: Survey question on emerging feed-in-control technologies

Grid management

On the field of grid management, half of respondent DSOs consider losses as a decision variable for network expansion or reinforcement (Table 6). As mentioned by a DSO, the main reason for investment is better safety of power supply, the secondary advantage is reduction of losses, resulting from a cost / quality optimization.

Question	Yes	No
Are losses a decision variable when making network expansion or reinforcement choices?	6	6

Table 6: Survey question on expansion / reinforcement

For network reconfiguration (table 7), reducing losses appears to be one reason within others for DSOs (and is often not considered) ; one booster may be smart-grid technologies (e.g. new Low Voltage control system).

Question	Yes	No
Have you started to work on Network Reconfiguration?	12	7
If "Yes", what impact has this brought to your networks?	Losses (4)	
If "no", why have you not started, and what is your future plan in this aspect?		Smart-Grid (2)

Table 7: Survey question on network reconfiguration

Only a minority of DSOs, situated in Asia or in Northern / Southern American, answer to have worked on Load Shifting, with losses reduction as a reason within others.

Question	Yes	No
Have you started to work on Load Shifting in your network?	5	1
If "Yes", what impact has this brought to your networks?	1 for loss reduction	

Table 8: Survey question on load shifting

4.4.2. Global approach on losses

Interesting plan for the development of a more efficient distribution network [11]:

- Within the next 3 months, identify areas where waste can occur: primary substations, MV feeders, secondary substations. Consider parameters such as density of population, power of existing and forecasted DER, strategy around smart metering, and existing communication options.
- Within the next year, install sensors and applications that can accurately assess the magnitude of the efficiency losses. Begin to identify areas of improvement.
- Within the next two years, implement pilot project to demonstrate feasibility, quantify the gains, and estimate the deployment costs.
- Within the next 10 years plan and implement the staged rollout [11].

It proves that TL mitigation shall be analyzed and planned on a long term period.

4.4.3. Smart-grid impact on losses

Smart Grid technology gives a possible to view topic in other context Table 9:

(with potential **H – High**, **M – Middle**, **L – Low**)

Type of measures	Scenario with SG opportunity	Scenario without SG opportunity
Component replacement	H	H
Energy efficient transformers	H	H
Increasing line capacity	H	H
Increasing voltage level	H	H
Feed in control	H	M
Distributed Generation	H	M
Energy storage	H	M
Grid management	H / M	M / L
Transformer switching	M	L
Network reconfiguration	H	M
Reactive power management	M	M
DER voltage control	M	M
Elimination of imbalance	H	M
Demand response management / Load smoothing	H	L
Regular inspection of the distribution equipment	M	M

Table 9: Mapping of the SG potential of each measure

Conclusion: Globally, smart-grid approach helps to locate network dysfunctions, and thus contribute to improve component optimization. But it mainly offers new possibilities for grid and feed-in control management.

4.4.4. Techno-economic approach

General principle

As for all investment decisions, DSO shall consider only the different methods for TL mitigation with profitable return on investment (ROI).

The techno-economic approach consists of comparing costs and benefits of the measure on a long term basis.

Indeed, the investment decision will have to take into account all techno-economic impacts such as investment costs (initial investment and final replacement) but also operational expenditures - including technical losses - and the assessment of the grid quality on the entire lifetime of the equipment.

In practice, technical losses are hardly a key factor in the investment decisions. But different situations may occur and lead to investments in solutions to mitigating TL solutions:

- Some kind of investments are mainly guided by technical losses such as cross sectional area decisions
- In some cases, losses cost does not trigger the investment decision but only influences on the chosen technical solution (energy efficient equipment)
- Sometimes, measures are taken - even if return on investment is not guaranteed - because regulator gives some incentive or because decrees to the effect are passed.

NB : Currently regulatory framework has considerable influence on the amount of TL, and maybe on costs of TL, due to behaviour of the stakeholders with positive or negative impact to losses (e.g. DG examples, energy efficiency programs on losses volumes or energy prices evolution on losses prices).

Application to DSO situation

Techno-economic approach has to be adapted for future investments decisions in all DSO situation :

- in developing countries, the objective is to achieve construction or reinforcement of the grid (e.g. upon the milestone of 90% electrification) with an optimized global cost where loss cost is negligible in front of non-quality cost
- in developed countries, the grid is assumed to be more efficient or of "good quality", and one will look at how the grid can be "upgraded". Losses become an issue, which remains nevertheless secondary compared to criteria regarding quality of service or obligations such as the integration of renewable energies

In all situations, it is crucial to assess the performance of the network (LV network): this information will contribute towards network management and future implementation of smart grids.

Price of energy issue

It is important to notice that one of the key factors influencing the final decision is the price of energy that shall be considered in ROI approach.

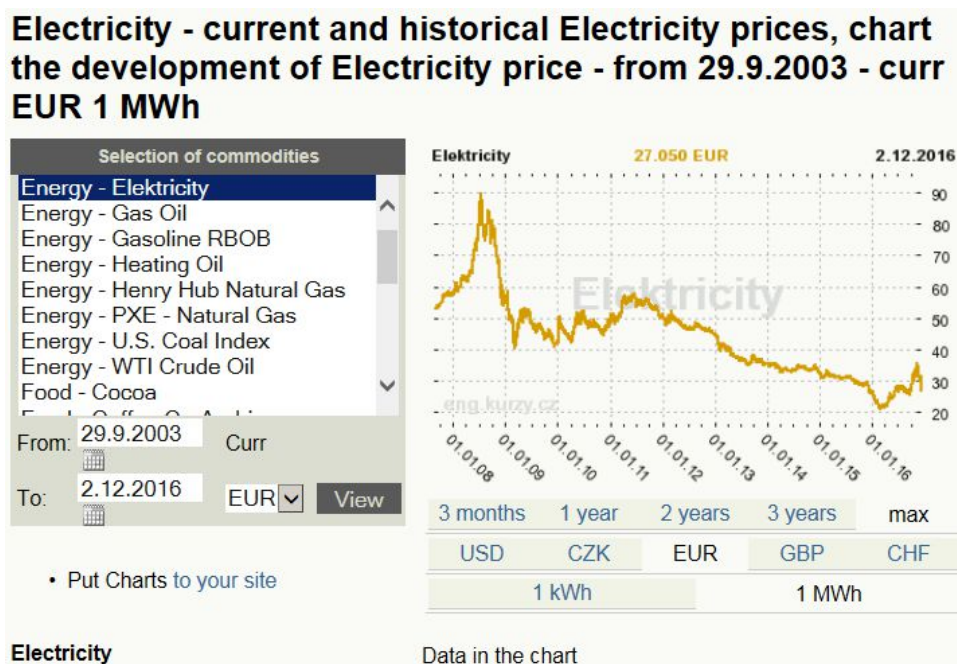

Figure 15 Electricity price on market [8]

In most cases, the market creates the prices (see Figure 16) and the huge prices variations (between 20 and 90 €/MWh between 2010 and 2016) make it much uneasy to prepare reliable prediction on a very long period (40 years - lifetime of transformers). This leads to high uncertainty on the ROI of investments that are strongly driven by benefits on TL costs.

Considering the high cost of mitigation action, TL reduction at any rate cannot be the best decision, especially when TL level (and energy price) is already relatively low. The cost of mitigation action should be compared to the cost of the losses themselves on a long term view, that may justify the consideration of a normative price in an appropriate regulatory framework.

DSO opinion on economic aspects

About half of DSOs have a specific budget to tackle losses, generally (but not only) in countries with high losses concern and with an amount that may be higher than 5% of total investment for some of them (Table 9).

Question	Yes (< 5%)	Yes (> 5%)	No
Do you have a specific budget to tackle losses? (% of total investment)	5	3	10

Table 10: Survey question on budget to tackle losses

In general, loss reduction is considered as one of the variables of a larger investment optimization plan (Table 10), but not the main driver for investments [7]. Penalties may also be a driver, not as a reward, but as a supplementary cost that shall be avoided.

Question	Increase benefit (*)	Avoid penalties
What type of ROI are you looking for in loss reduction projects?	6	6

Table 11: Survey question on ROI for loss reduction projects

(*) or minimisation of total life time costs

4.5. CONCLUSION

1/ The analysis of the different types of the TL shows that TL structure and level are very specific to each distribution network.

2/ This paper describes and classifies some possible methods for TL reduction with three categories (Component / Feed-in-control / Grid Management) and two main issues:

1. The methods that can be boosted by smart grid approach
2. The question of geographic proximity and time synchronism for DG impact on losses (reduction vs increment)

3/ TL limitation is a complex equation with many variables: Distribution system operators shall consider the different methods aiming to mitigate TL with a technical-economic approach promoting network achievement at an optimized cost in developing countries and quality of supply rather than losses in developed countries.

4/ Regulation is a key factor to solve this difficulty, in favouring cooperation between stakeholders and adopting a more global approach:

- Tariff may provide DSO a long-term financial framework with favourable incentives to find a balance between investment costs borne by the client and the stakes related to losses. This, either way, renders that dynamic quite slow (ex: in Great Britain, effects of the measures initiated will be monitored over a period of 8 years).
- As an example, research programs on the field of smart grid have a large potential to boost both a solution for losses reduction and for power quality improvement.

5. NON-TECHNICAL LOSSES

5.1. INTRODUCTION

5.1.1. Definition (reminder of previous content)

Non-technical losses primarily relate to unidentified, misallocated and inaccurate energy flows. In essence it represents the amount of energy that is delivered but not accounted for. The types of NTL are summarized in Fig 1.

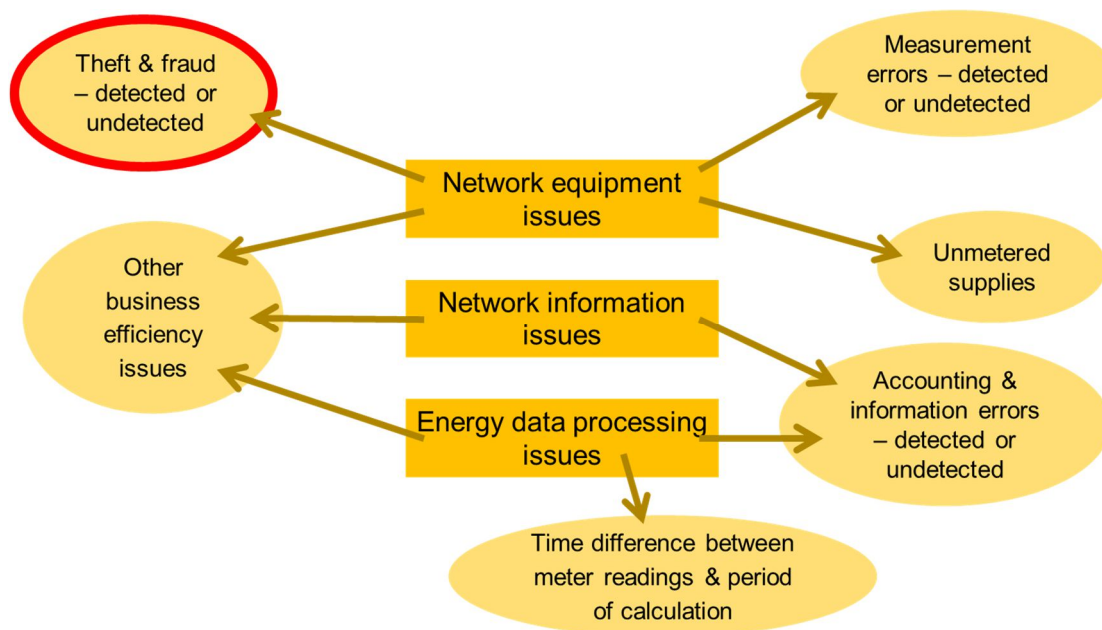

Figure 1: Summary of types of NTL

The aim of this chapter is to estimate the size of NTL in various regions around the world and to explore measures that have been used successfully in reducing the size of NTL. The chapter ends with a recommended method for reducing NTL, based on the experiences reported, and with a list of methods that could also be used for tackling technical losses (TL).

5.1.2. Classification

Theft and fraud

The literature indicates that theft and fraud, circled in red, in Figure 1, make up the largest component of NTL – it certainly receives the most attention – and may take the following forms:

- Illegal connections to the distribution network – these connections are not immediately known to the utility and hence they are not metered.
- Illegal re-connections – where a customer reconnects their supply when they have been disconnected, again the utility may not be metering and charging for this energy.
- Bypassing or other tampering with the meter to either avoid paying for electricity or to reduce the amount that is billed.

Examples of the above are shown in Figure 2. Actions such as those shown can have serious safety implications. For example, in order to bypass a meter of the type shown on the left of the figure the entire meter, which includes the residual current device (RCD), is bypassed, leaving the installation unprotected. Illegal connections to the network likewise have inadequate protection and live parts may be exposed.

The additional power flows due to illegal connections may also lead to network equipment being over-stressed, this may lead to overheating or even explosion of this equipment, which may cause injury to people.

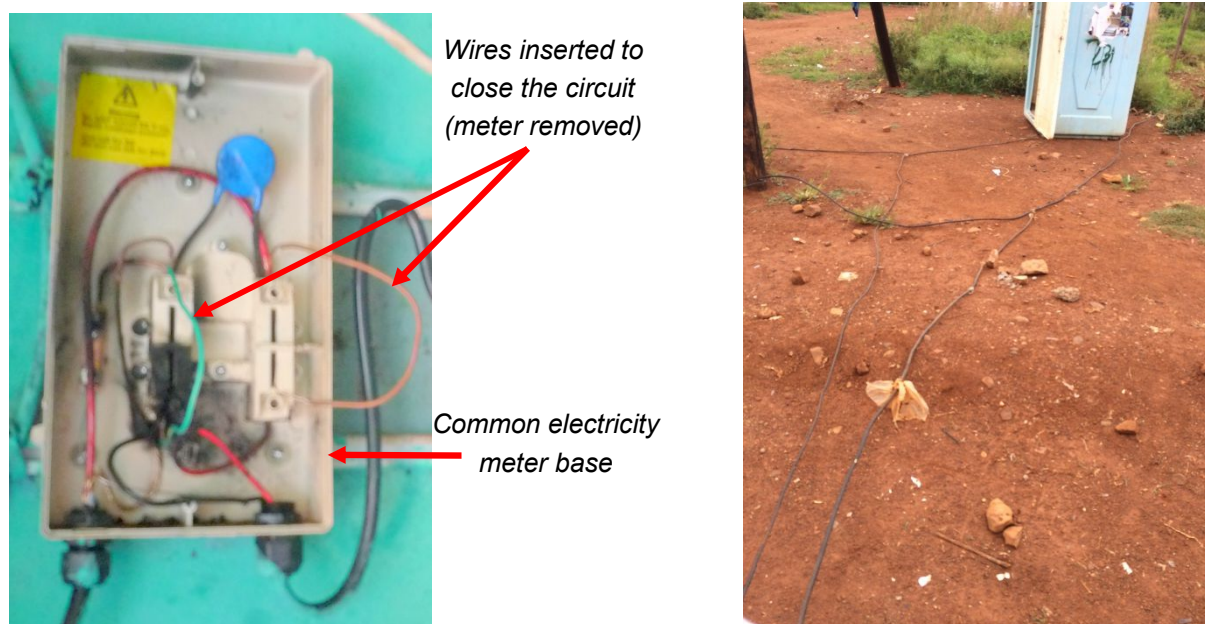

Figure 2: Examples of a bypassed meter (left) and wires illegally connected to the low voltage network (right) [Beutel 2015]

Business inefficiencies

All other types of NTL may be broadly defined as business inefficiencies or uncertainties. Measurement errors occur in the metering equipment and can result in the energy usage being under (or over) read, resulting in less energy being recorded than is actually being used. Accounting and information errors are errors or inefficiencies in business processes.

Unmetered supplies are either supplies not metered in error or, more likely, cases where the energy usage of certain customers is estimated rather than measured or where certain customers are purposefully not charged. In a similar way, some supplies may be correctly measured, but not correctly contracted, with the same result of customers not being charged.

Time difference between meter readings and period of calculation refers to energy usage estimations that have to be made when losses are calculated for a defined period (e.g. a month or a year) but the meter readings for the end date (e.g. 31st Dec 24h00) or for the start date (e.g. 1st Jan 00h00) are not available.

Meter malfunction

Meters may malfunction for several reasons, due to internal component fault or external environment hazard, although overall this is a rare occurrence. An example is shown in Figure 3. Tampering may also appear as meter malfunction.



Figure 3: Example of a meter infested by ants

5.1.3. Macro-economic environment/framework

NTL are generally considered to be higher in developing countries than in developed countries, because most people in the latter can afford to pay cost-reflective tariffs [Antman 2009], but they are by no means non-existent in developed countries. This is supported by analysis of World Bank data for 2000, which shows that regions apart from Western Europe, North America, Southeast Asia, East Asia and Australasia have significant levels of NTL (the threshold being taken as total T&D losses of 16% or more) [Smith 2004].

Many utilities in developing countries have managed to significantly reduce NTL, but other utilities continue to experience significant NTL [Antman 2009]. A substantial portion of NTLs are caused by users who can afford to pay, e.g. high-energy industrial or commercial premises, so NTLs can in many cases be reduced with little or no loss of welfare [Antman 2009].

5.2. SIZE OF NTL

5.2.1. Global view

This may be summarized in Table 1. This table summarizes the more detailed information covered in Appendix 7.2.1¹ (More detail around NTL types and extent), references are included at that point.

Table 1 shows the following:

1. In many cases estimates vary for the same country. The level of losses may vary even within the same country, depending on the region [ERGEG 2009].
2. Separating technical losses (TL) and NTL is not always an easy task [ERGEG 2009] [SPEN 2014], hence the fact that TL and NTL are often combined, in some cases transmission and distribution losses are also combined.

Europe	<ul style="list-style-type: none"> • Total distribution losses range from 2.3% (Sweden) to 11.8% (Poland), with Romania (13.5%) and Turkey (19% due to theft alone) being outliers. • An example of an extreme outlier is a village in Romania which had total losses of 84%; these were subsequently reduced to 26.1% (9.7% of which were TL).
Asia	<ul style="list-style-type: none"> • India: total losses vary significantly between utilities and between estimates – 11% to 58%. • Pakistan: > 30% total losses. • Bangladesh: > 20% total losses. • Indonesia: 7% losses due to theft. • Malaysian peninsular: estimates vary from 11-15% (NTL only or total T&D losses). • Thailand's public system has total T&D losses of about 11%.
North & Central America	<ul style="list-style-type: none"> • While the presence of NTL, particularly energy theft, is well known in Mexico, the actual percentage loss has not been published. The annual cost is estimated to be \$475 million. • The USA also has NTL and again the percentage is not known, but annual costs likely run into the billions of \$.
South America	<ul style="list-style-type: none"> • Brazil: an estimated value of 7.3% - 25% of the energy supplied to the distribution systems is lost to NTL. • Chile: one utility reduced its total losses to 5% from 22%.
Middle East & Africa	<ul style="list-style-type: none"> • Sub-Sahara: only 50% of electricity usage is paid for; Botswana is the best performing (10%). • As much as 7% of energy produced in South Africa is through to be lost to theft alone. • Over 50% of the business customers of one South Africa utility were found to have bypassed their meters. • Senegal: 21% total losses. • Uganda loses about \$30 million per year to electricity theft. • Jordan: total distribution losses are in the 12-14% range.

Table 1: Size of NTL around the world

Conclusion: losses measurement is a necessary preliminary step to evaluate losses reality and to focus on areas with high loss levels.

¹ Some figures are also taken from Appendix 7.2.2, where the effectiveness of mitigation measures is discussed.

5.2.2. Detailed view

A selection of countries from the survey performed for this report is ranked qualitatively in terms of importance assigned to various root causes of NTL, as taken from the survey results, in Table 2. This shows broad agreement with the literature, including the expected wide range of losses and priorities between countries in Europe, as discussed further in Section 6.2. Priorities may vary between DSOs, even in the same country (Cf. US). This makes it difficult to analyze these results and hence to draw generalized conclusions, opening the results up to subjective opinions. For example, it is not immediately known whether low priority assigned to NTL is due to efficient mitigation measures or limited financial impacts.

The only conclusion possible is that there are countries not significantly concerned about losses, either because their losses are low or because their regulation doesn't penalize them. There are therefore two possible conclusions regarding DSO's attitudes towards NTL:

1. Weak concern about losses: either because their losses are low or because their regulation doesn't penalize them.
2. Strong concern about losses: priorities may vary between DSOs according to their specific situation either on TL or NTL issues.

Root Cause	Swed.	Austria	Japan	UK	China	Indonesia	US	Slovenia	Italy	France	Portugal	Spain	Brazil
Losses priority	Low			Medium				High					
Detected Theft													
Detected Meter Error													
Detected Incorrect Info of Connection Point													
Non-metered Supply							(*)						
Time-Lag between Meter Reading and Calculation													
Undetected Theft							(*)						
Undetected Meter Error							(*)						
Undetected Incorrect Info of Connection Point							(*)						
Other Unidentified Source							(*)						

Table 2: Qualitative ranking of a selection of countries with respect to root causes of NTL

(*) : average value with wide variation in the answers given by different DSOs

5.3. MITIGATION OF NTL

5.3.1. Main principles

The main principles have been identified from the more detailed study presented in Appendix 7.2.2 (Mitigation of NTL), and may be categorized as shown in Table 3.

Dimension	Global	Local
External to the DSO	Regulation	Customer
Internal to the DSO	Measurements & IT systems	Field force

Table 3: Summary of NTL mitigation measures

The principles are now defined.

External

1. Regulation:
 - The regulatory framework must be adequate to incentivize loss reduction in a realistic way with e.g. setting of realistic loss targets and bonuses.
 - Electrification of previously un-electrified areas (where illegal connections are known to be rife) has also had good results as many customers now pay for electricity usage.
 - Privatizing state-owned utilities has as a general rule shown to improve business efficiency, but Appendix A shows that this can also have the opposite effect.
2. Customer:
 - Good relationships with customers are also important, as this allows for the speedy resolution of problems and hence lower risk of customers taking matters into their own hands. Large power users are especially important in this respect since they often have the largest incentive for theft.
 - Customer education is an important component of any intervention, as it not only makes the customer aware of the legal or financial implications of electricity theft but also educates them with respect to the safety risks.

Internal

1. Measurements and IT systems:
 - Accurate measurement of NTL is crucial, as this allows not only detection of the presence of NTL but also the amount and location of losses, allowing prioritization of areas for mitigation. One way of implementing this is by using central check/observer/supervisory meters (also known as energy balancing).
 - Improving utility business efficiency generally, e.g. implementation of advanced IT systems, is also very important, as this reduces the risk of metering or billing errors. Improving maintenance and inspection falls under the same category.
 - Improving technology and network design can make NTL less likely.
 - Several data analysis methods are available, but these are only as good as the utility systems that support them. Only a few of these methods have been successfully used in the field.
 - Smart meters² have significant potential for NTL identification, location and reduction, on their own or as part of a wider system, and are already being used to good effect in several countries.
2. Field force:
 - Dedicated NTL reduction teams are used in several countries to detect and address fraud.
 - When implementing mitigation measures, the largest users of electricity should be tackled first, for the reasons mentioned above, and large customers found to engage in theft should be “named and shamed” and prosecuted, even if politically connected.

² The meters may either be placed in the customer’s premises or out of reach of the customer with just a customer interface unit in the premises (split meter).

5.3.2. NTL mitigation using data mining

NTL mitigation may be improved by two types of data mining, which are illustrated in Figure 4:

- Statistical regular approach, and
- Big data and Smart meters approach.

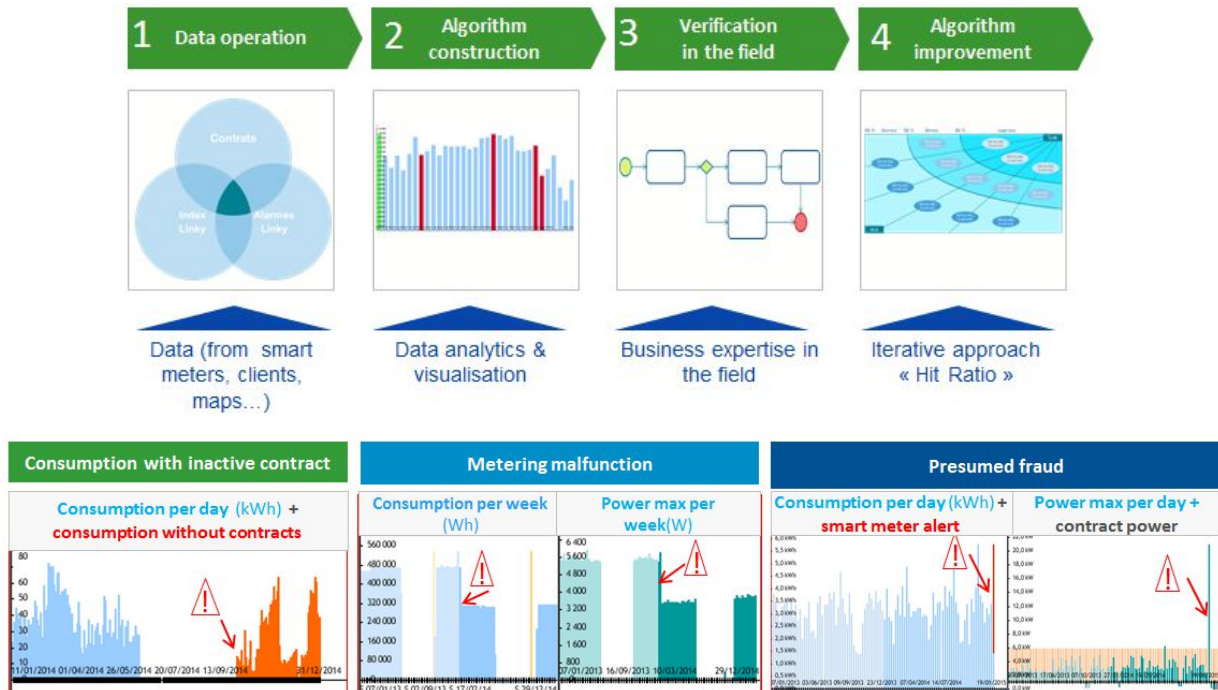

Figure 4: The process of data mining (above) and applications on customer data mining (below) (courtesy Enedis)

Data mining can be used as a tool for optimizing inspections in the field, by steering them to specific areas or locations suspected of fraud, rather than sending teams on blanket inspections. Inspection locations can also be ranked by importance. It is a continuous process that involves statistical modelling, with the models updated with results from the field. This is illustrated in Figure 5.

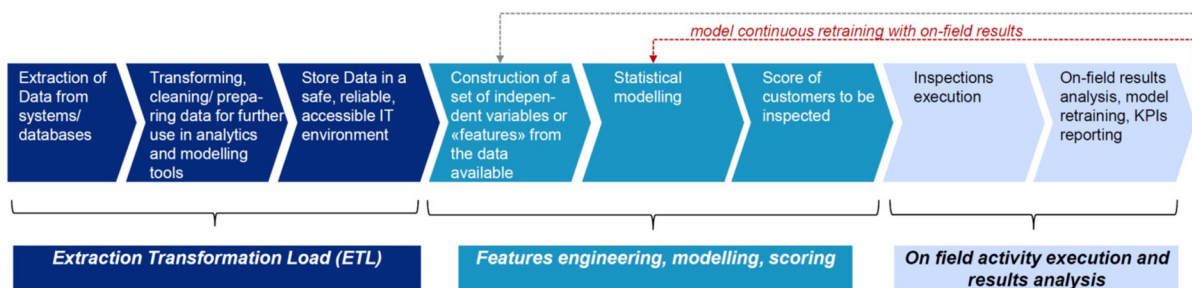

Figure 5: Step-by-step data mining process (courtesy ENEL)

Note that installing smart meters is not required to perform data mining, as long as an adequate amount of input information is provided. Smart meters provide more information than if such meters are not installed, improving the analytics, but data mining is not limited to smart networks.

Further details of specific methods of data mining may be found in Appendix B, specifically in sections 7.4 and 7.9.

5.3.3. NTL mitigation with smart meters

Smart meters can drastically improve the effectiveness of a data mining solution, by detecting events such as attempted tampering. Examples of what can be achieved using smart meters and related IT systems are shown in Table 4.

Minimum losses per month to justify an investigation to find and correct electricity theft [Doorduyn 2004]	
% electricity theft per month	Investigations per year
4.82	1
9.65	2
14.4	3
19.3	4
24.1	5
28.9	6

Table 4: A proposed set of criteria for actions based on theft identified via energy balancing

However, the statistical approach (data mining) is not the only possibility as energy balancing can be performed (depending on the amount of meters deployed in the network analyzed) by simple differences between the energy inflows and outflows in a specific area.

An illustration of the principle, using a hypothetical example, is shown in Figure 6. The sum of the energy recorded by each customer meter should add up to the energy outflow recorded at the secondary substation (minus calculated TL). If not, then some form of NTL (and/or higher TL) is present and should be investigated.

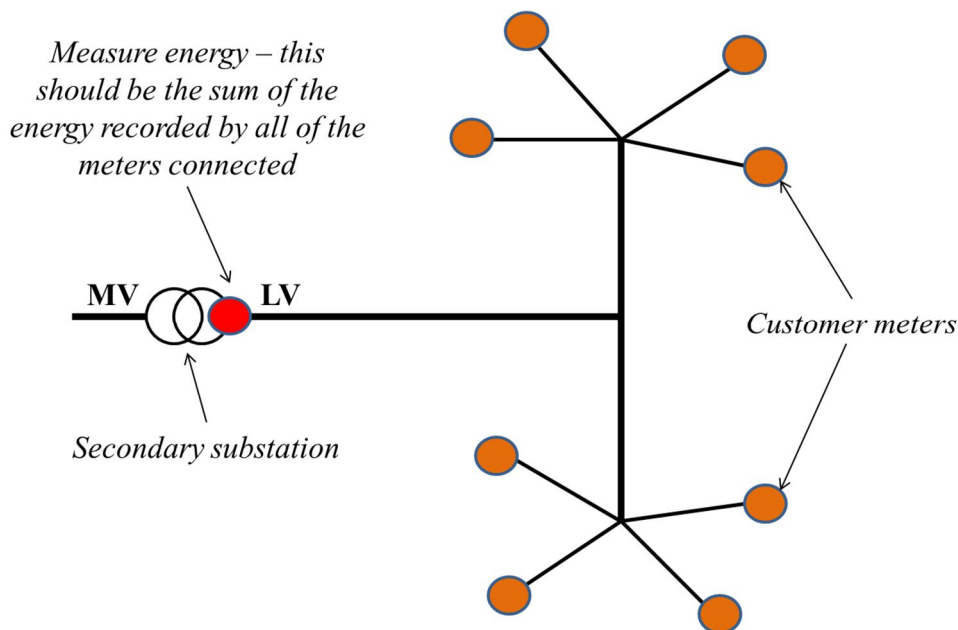

Figure 6: Illustration of the principle of energy balancing

A real-world implementation of this principle by the Spanish DSO Iberdrola is shown in the Figures 7-11 (3.5 million supply points representing $\approx 30\%$ of the total supply points of Iberdrola Distribution Spain).

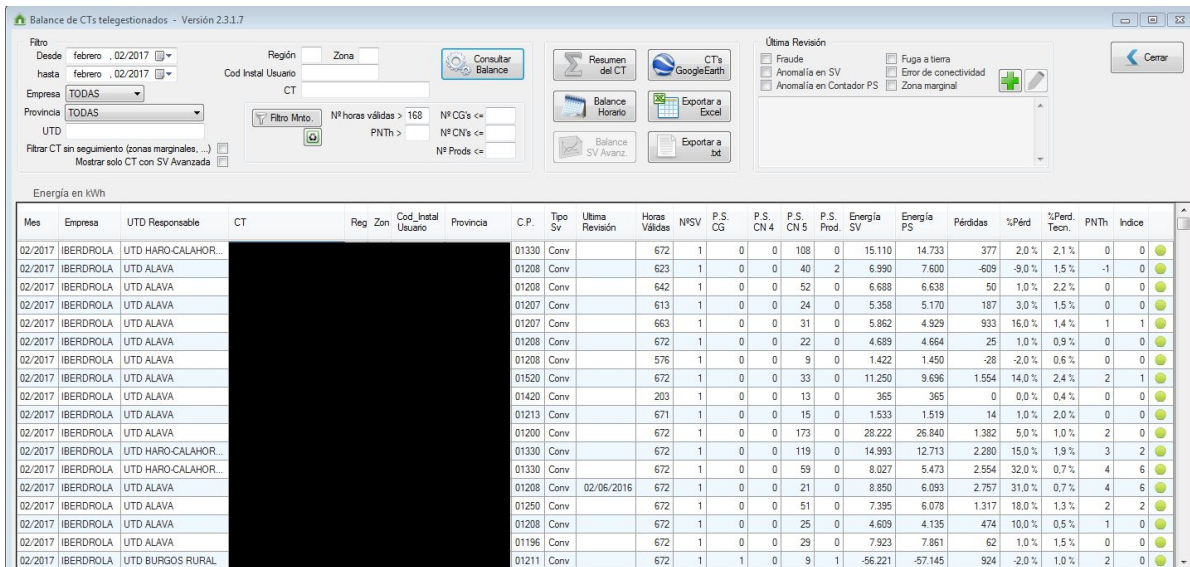

Figure 7: Illustration of the monthly ranking of losses per secondary substation

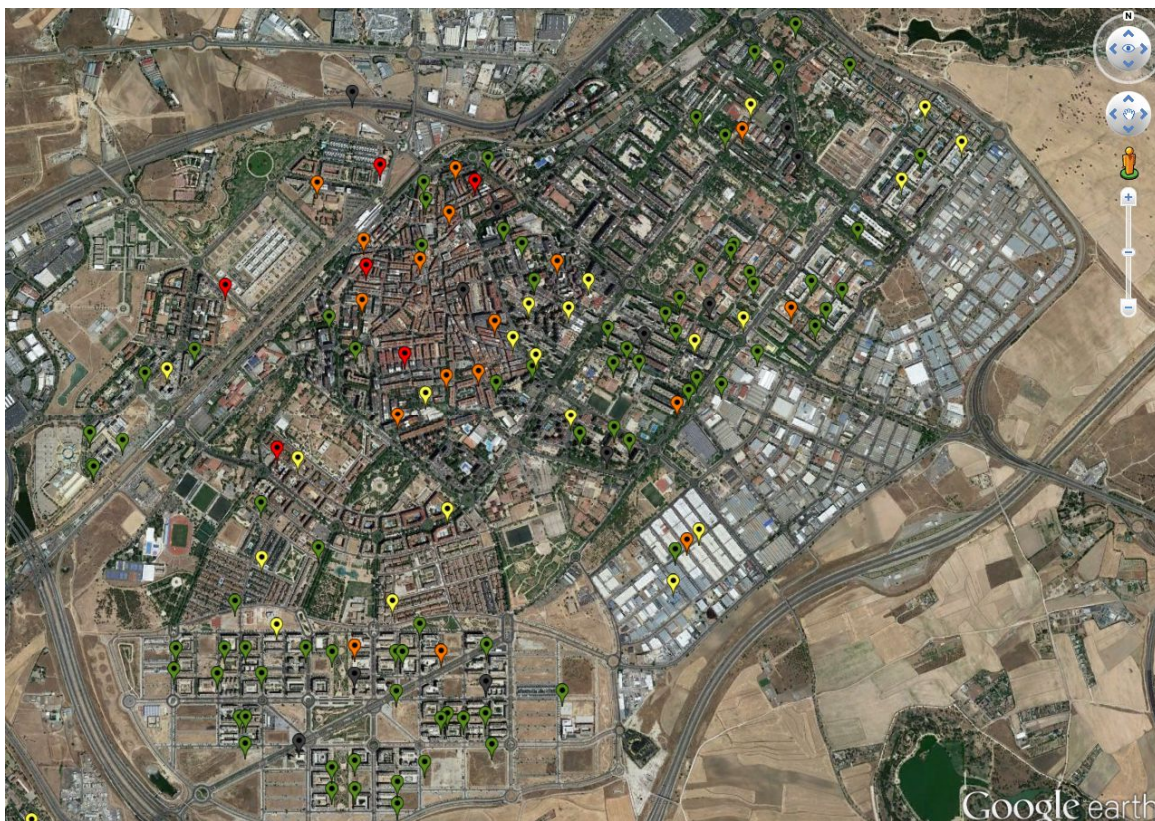

Figure 8: Geographic representation of areas of the monthly ranking (identifying areas of suspected NTL)

Empresa	UTD Responsable	CT	Reg. Zon	Cod. Instal. Usuario	Provincia	PS 2y3	PS 4CG	PS 4CN	PS 5	Prods	Tipo Sv	Ultima Revisión	Feb 2016	Mar 2016	Abr 2016	May 2016	Jun 2016	Jul 2016	Ago 2016	Sep 2016	Oct 2016	Nov 2016	Dic 2016	Ene 2017	Feb 2017	Mar 2017	
IBERDROLA						0	0	0	8	0	Conv	06/04/2017	0	0	0	0	0	0	0	0	0	0	0	11	24	25	31

Figure 9: Average losses per month on the substation under suspect

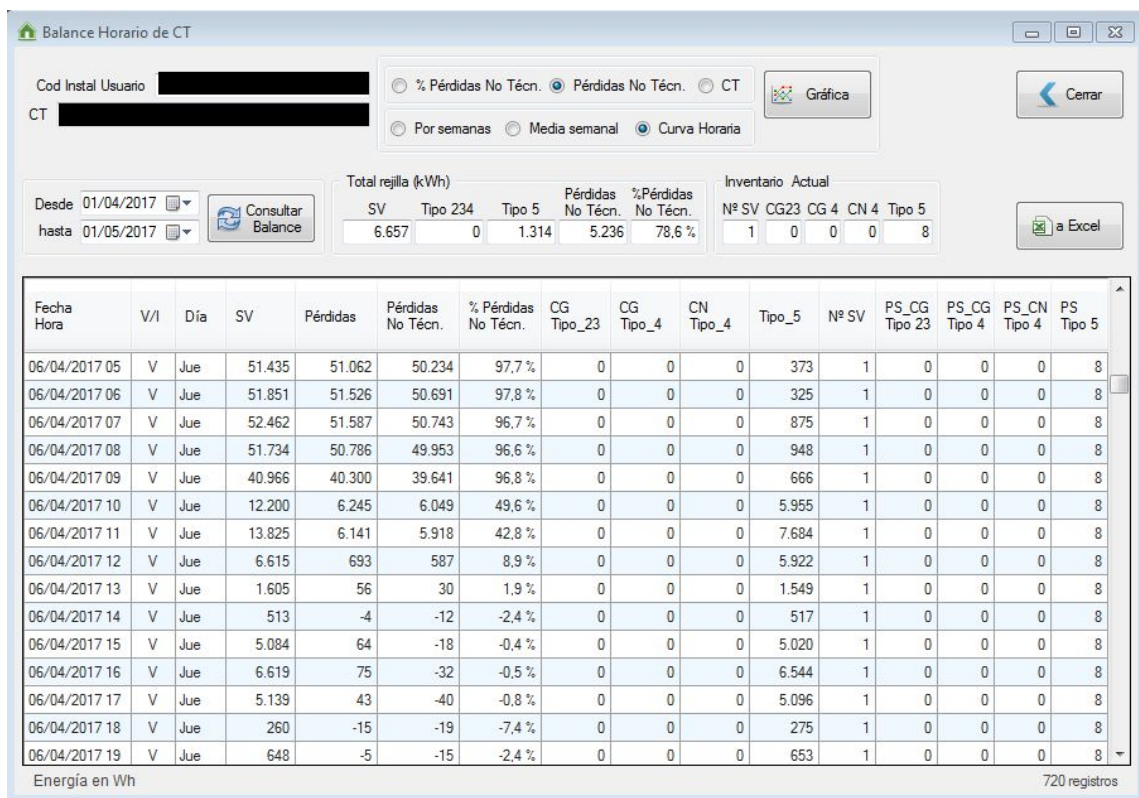

Figure 10: Inspection day/hour selection in a weekday/hourly basis (higher losses values)

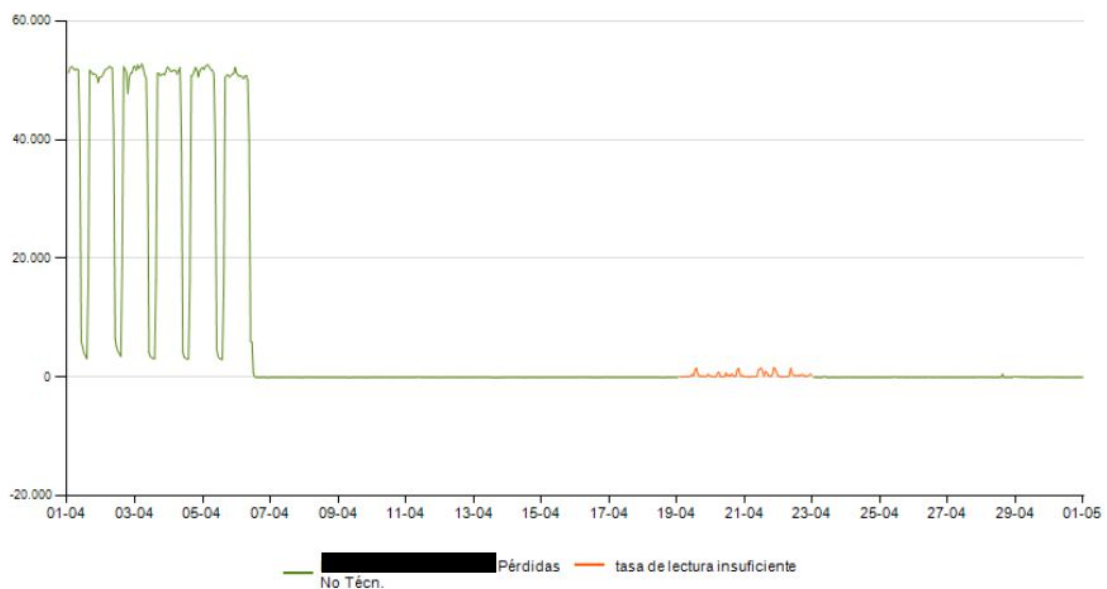

Figure 11: Graphical outcome check – illegal connection to the network on the substation reviewed (detected and corrected 6th April)

Further details around energy balancing may be found in Section 7.8.

5.3.4. Mitigation of theft and fraud

The advanced techniques covered in the preceding sections can be used to detect theft and fraud, as shown in Table 5. The response to suspected detected theft and fraud would vary, depending on the conditions at the specific location, e.g. whether it is safe or not to investigate. These methods can also improve TL models with a better LV representation (network connection, load etc.).

Data mining and energy balances are two complementary methods that can be applied considering the type of NTL.

Category of NTL	Origin of NTL	Approach
Theft / fraud	Bypass / meter tamper (recent)	Energy balance (P or E difference) or Datamining (P or E drop)
	Bypass / meter tamper (old)	Energy balance (P or E difference)
	Illegal direct connection (no meter)	Energy balance (P or E difference)
Other NTL	Meter uncertainty (recent)	Energy balance (P or E difference) or Datamining (P or E drop,)
	Meter uncertainty (old)	Energy balance (P or E difference)
	IT uncertainty (recent)	Energy balance (P or E difference) or Datamining (P or E drop,)
	IT uncertainty (old) including GIS errors	Energy balance (P or E difference)

Table 5: Mitigation approach depending on type of NTL

5.3.5. Other measures

Other measures that have been found in the literature are listed below.

Equipment-related measures

- Tamper-proof meter boxes (Figure 12) and other security materials, as tamper-proof numbered seals³.
- Reduction of the average number of consumers per transformer.
- Reducing the length of LV feeders⁴.
- Split meters and meters located in the distribution box of the transformer point.
- Prepaid meters.
- Replace transformers with lower power ratings and improved protection.
- Upgrading of electricity meters.
- Smart card technology (to minimize the theft of energy).
- Statistical monitoring of energy consumption.

³ According to meter types and communication means, different types of seals are available, e.g. traditional types and more modern electronic types (both of them could be complementary).

⁴ Reducing LV feeder length means that there is less network that can be easily tampered with (the rest is MV which is much more difficult to connect to). This measure also contributes to reduce TL.

Utility process-related measures

- Energy audits/targeted inspections.
- Providing adequate means of testing meters.
- Schedule for checking meters and replacing defective meters.
- Updating records to remove errors.
- Liaison with all appropriate stakeholders.
- Providing internal training and awareness.

Law enforcement-related measures

- Investigate parties who applied for a connection but didn't complete the process.
- Enacting strict laws and improve their enforcement.
- Apply all reasonable safety measures when an illegal connection is detected.

Use of as many measures simultaneously as possible is encouraged, e.g. technical measures such as implementation of smart meters and legal measures such as prosecuting offenders. However, the cost of mitigation measures should be compared to the cost of the losses themselves – if the measures cost more to implement than the cost of the reduced losses then there is no incentive to implement them.

Refer to Appendix B for further information.

5.4. RECOMMENDED METHODS OF REDUCING NTL

5.4.1 Global view

The principles listed in Section 3 are used to compile a proposed method, which is approached from a utility (DSO) perspective. The first step in compiling this method is to group the various principles (actions) into approaches, i.e. regulation (engagement with regulatory authorities), capital investment, organization (business processes) and (customer behavior and) communication. This is done in Table 6. This table also has a column for identifying which actions can also be used to address technical losses (TL) and an additional row for additional technical measures.

Action		Regulation	Capital investment	Organization	Communication	Also TL
External to DSO	Electrification of previously un-electrified areas, where illegal connections are known to be rife	X	X	X	X	Negative effect
	Good relationships with customers			X	X	
	Engage regulatory authorities to adequately incentivize loss reduction and put appropriate regulation and laws in place	X				X
	Customer education and awareness				X	
Internal to DSO ¹	Accurate measurement, detection and location of NTL	X	X	X		X
	Implementation of smart meters and corresponding support systems (these could also be split and/or prepaid meters)	X	X	X	X	X
	Improving utility business efficiency generally		X	X		X
	Improving technology and network design to make NTL less likely		X	X		X
	Dedicated NTL reduction teams, including adequate legal and logistical backup			X	X	
	Tackle the largest users of electricity first, including prosecution, publicity and other related measures			X		
	Data analysis to support all of the above, including data collection process and data quality validation		X	X		

Table 6: Actions (rows) and approaches (columns) for tackling NTL

¹ Colours refer to improvements in metering, operating efficiency and analytics.

Conclusion: NTL mitigation results from a combination of various complementary actions. The exact measures employed should be decided according to the level of losses experienced by the DSO and according to the unique circumstances of the DSO.

The actions in Table 6 are now applied to the different scenarios of DSOs, which are illustrated in Table 7.

5.4.2 Effect of socio-economic conditions

Socio-economic conditions are a major input when deciding which NTL mitigation measures to employ. Areas may be classified depending on those areas:

- Traditional areas:
 - Areas where traditional methodologies (inspections, normalizations and the like) are sufficient to effectively control the level of fraud and theft.
 - Mitigation measures include more productive inspections by improving targeting of campaigns, energy balancing, data mining and other advanced equipment and process-related measures.
- Complex areas:
 - Areas where the support of law enforcement is needed in order to perform traditional fraud and theft mitigation measures. These are usually areas in which traditional methodology applied for NTL mitigation have a short effective life, because of immediate recidivism of theft and frauds. In these areas, more robust installations are needed in order to prevent fraud and theft.
 - Mitigation measures include anti-theft technical solutions such as prepaid meters and remote meter reading, armoured meter boxes, armoured tubes for connections (up to the top of the pole), coaxial connections or even armoured cables, split metering on top of the pole and remote alarms for meter boxes. Examples of armoured boxes are shown in Figure 12.
- Risky areas:
 - Regions that are usually strictly delimited (e.g. slums or favelas) in which the social context hinders or even prevents any access to the premises in order to inspect or solve any kind of anomaly. In the worst situations of this kind, even low enforcement is ineffective. In these areas neither the traditional nor the more robust solutions are effective, and losses may grow uncontrollably.
 - Mitigation is usually by regulation such as social studies to objectively demonstrate the social situation and lobbying with regulatory organizations to obtain higher recognized losses. DSO sustainability and communication functions also play a key role in creating a culture of legality, to improve local economy and hence improve incomes, to promote energy saving policies and safety campaigns reduce the risk of electrocution.



Figure 12: Examples of mitigation measures that could be employed in complex areas (courtesy ENEL)

5.4.3 Smart meter readiness

Dimension	With opportunity for smart meter deployment	Without opportunity for smart meter deployment
Developed countries	Scenario 1	Scenario 2
Developing countries	Scenario 3	Scenario 4

Table 7: Grouping of DSO scenarios

The scenarios are defined as follows:

- Scenario 1: DSO in developed country with smart meters already in place, or in the process of being rolled out.
- Scenario 2: DSO in developed country with no immediate plans to roll out smart meters.
- Scenario 3: DSO in developing country with smart meters already in place, or in the process of being rolled out or the capability to implement smart meters.
- Scenario 4: DSO in developing country with no capability to implement smart meters.

The cost-to-benefit ratio of each action is ranked for each scenario, the results are shown in Table 8. The ranking is qualitative, based on the information in Appendix B, and may vary depending on the unique circumstances of each DSO.

Action		Scenario 1	Scenario 2	Scenario 3	Scenario 4
External to DSO	Electrification of previously un-electrified areas, where illegal connections are known to be rife	M	M	H	H
	Good relationships with customers	H	H	H	H
	Engage regulatory authorities to adequately incentivize loss reduction and put appropriate regulation and laws in place	H	H	H	M
	Customer education and awareness	H	H	M	M
Internal to DSO ¹	Accurate measurement, detection and location of NTL	H	M	M	L
	Implementation of smart meters and corresponding support systems	H	M	M	L
	Implementation of prepaid meters ²	L	L	M ³	M ³
	Improving utility business efficiency generally	H	H	H	H
	Improving technology and network design to make NTL less likely	H	H	M	M
	Dedicated NTL reduction teams, including adequate legal and logistical backup	H	M	M	L
	Tackle the largest users of electricity first, including prosecution, publicity and other related measures	H	H	H	H
	Data analysis to support all of the above, including data collection process and data quality validation	H	M	M	L

Table 8: Actions ranked in terms of cost-to-benefit ratio (financial impact) for the above different scenarios – H (highest benefit), M (moderate benefit), L (smallest benefit)

¹ Colours refer to improvements in metering, operating efficiency and analytics.

² This may also be considered as an aspect of “Improving technology and network design”.

³ Impact depends on various factors, including socio-economic.

Table 8 shows that most actions are expected to have a high financial impact for scenario 1, i.e. a DSO with smart meter capability in a developed country. A DSO in a developed country without immediate smart meter capability can still reduce NTL in a relatively short space of time, but measures that are data intensive will be more costly to implement than for scenario 1 and therefore would have a lower cost-to-benefit ratio. In such a case the DSO may be better advised to use other measures, e.g. educating and building relationships with customers, before implementation of smart meters and advanced network monitoring.

A DSO in scenario 3 would in many ways be in a similar position to one in scenario 2, but may have greater scope for electrifying un-electrified areas since there may be more areas that are not yet electrified. The DSO with the largest challenge is one in scenario 4, since it is likely difficult to obtain accurate data; for such a scenario “smart” interventions would have the lowest chance of success and engagements with large power users, electrification of un-electrified areas and the like would have the best chance of success.

The impact of actions in all scenarios also depend on the level of losses experienced before implementation of the actions – the higher the losses prior to implementation, the higher the impact of mitigation actions is likely to be. This should also be considered when evaluating mitigation actions.

In all scenarios, the more actions that can be applied simultaneously (within reason) the better. Also, each action can have different ways of being implemented. For example, some of the additional measures listed in Section 3.5 may be grouped as follows:

- Technical measures can involve implementation of tamper-proof meter boxes and tamper-proof numbered seals, split meters, locating meters in the distribution box of transformer points, reduction of the average number of consumers per transformer, reducing the length of LV feeders, replacing transformers with lower power ratings and improved protection and switching and implementation of smart card technology.
- Actions undertaken by dedicated NTL reduction teams can include energy audits or targeted inspections, testing of meters and replacement of defective meters and upgrading of meters.
- Improvements to business efficiency may involve updating or correcting of records, providing internal training and awareness and investigating parties who applied for a connection but didn't complete the process.
- The regulatory authorities could be engaged to facilitate enacting strict laws against energy theft and improving their enforcement.

The impact of regulation in smart network development should be noted. For example, in UK the distribution company does not have access to the customer meters (only the retailer has access), and the retailer does not necessarily have access to the measurement in the secondary substations (check/observer/supervisory meters) as they are distribution companies' equipment. In such cases regulation makes it difficult or impossible for the utilities

to better use the information generated by smart networks as it is split between two different businesses.

In developing countries, social pressures such as community resistance to measures such as implementation of smart and/or split meters can make NTL reduction very difficult. In essence, technology cannot be used to solve social problems, and so the problem of electricity theft and fraud becomes a societal one, rather than a DSO issue (even though the DSO has to deal with the loss of revenue and is hence in a very difficult position).

The above are examples only, further measures may be found in Appendix B.

5.5. CONCLUSIONS

The key findings about NTL and their mitigation may be summarized as follows:

5. The limited experience with **smart technologies** in this application is that they are in principle very good at tackling NTL. However, for them to be successful **the business processes and funding need to be in place within the DSO** and correctly adapted to adequately support this, and
6. The **regulatory and general socio-economic conditions** in the country need to be able to support smart technologies and their use does not alleviate the need to also **pursue non-technical (traditional) measures** such as fostering good customer relationships, regular community engagements, law enforcement and the like.

The conditions and environment specific to each DSO need to be considered, as these may alter the most effective NTL measures from those listed for different scenarios in this document.

6. REGULATION LEVERAGE

6.1. INTRODUCTION: SOME QUESTIONS ABOUT REGULATION OF LOSSES

The previous parts of the report have revealed that the reduction of losses is a complex issue/problem (au choix):

1. Technical Losses represent a physical phenomenon and cannot be reduced to zero : their “acceptable” or “efficient” level depends on the specificities of networks (structure, flows etc).
2. Non-Technical Losses are, in general, evaluated by a global measurement, but may arise out of different factors located either on the network (theft, ...) or on DSO processes (on meter to bill chain). These factors need to be correctly specified and weighted before defining relevant mitigation actions.
3. TL and NTL mitigation actions depend on a technical and economic approach and require a positive ROI to allow a concrete application on DSO process, either for investments (AI, IT, ...) or operations (analytics, field teams).

As global losses represent a global challenge for the electric system, the first objective of regulation should be to set to the “right” economic level, with relevant incentives to all concerned actors.

Consequently, here are some of the key questions that regulation has to address :

1. How to define and measure an efficient level for losses?
2. What is the role of each actor in the mitigation/reduction (au choix) losses?
3. How regulation can help actors in their roles?

This section of the report proposes different steps to answer to these questions :

1. An overview of the situation of different actors with respect to regulation (Cf. WG survey results).
2. An analysis of the possible scenarios of losses regulation, with concrete illustrations.
3. A synthesis of these scenarios, including key points aiming to foster the TL and NTL mitigation approaches previously presented in the report : these approaches are detailed according to each DSO, with a specific point of view on its economic situation and smart meter strategy.

6.2. AN OVERVIEW OF THE DIVERSE DSO SITUATIONS (SURVEY RESULTS)

This section of the report presents the main results from the survey conducted by the Group related to the regulatory issues (Nota-Bene: no answer for DSO from USA).

Actor in charge of losses payment

The situation is quite balanced between countries with DSO or supplier payment, with the specific case (*) of integrated companies in China, where the responsible is the power company (i.e. the owner of assets) is responsible for the losses (Table 1).

Question	DSO	Supplier	Other (*)
Who pays for TL and NTL on the distribution network?	7	6	1

Table 1: Survey question on actor in charge of TL / NTL payment

In case of DSO payment, the cost is finally transferred to consumer through network fees, as it is in case of supplier payment with supplier offer (Table 2).

A special case worth mentioning is Indonesia, where the cost the cost of power losses is not transferred to the customer, but calculated by the DSO as the cost of production of electricity, which will be the input cost calculation of subsidies from the government (in the DSO income statement).

Question	Yes	No
If the DSO pays for losses, is this cost transferred to consumer?	6	1
If the DSO pays for losses, is it kept in the income statement?	3	1

Table 2: Survey question on cost transfer to customer

Regulatory constraints and incentives

A majority of countries have regulatory constraints and incentives for losses, but more widespread on prices than on volumes (Table 3). The regulation framework on losses may be either a constraint (tariff penalty) or an incentive (tariff reward).

Is there a regulatory constraint and incentive for your company with regards to management of distribution losses?	Yes	No
On volumes	10	6
On prices	13	3

Table 3: Survey question on regulatory constraint and incentive

The regulation period duration is in general between 3 and 5 years (Table 4), with some notable exceptions:

- 1 year period for an integrated company in China and even 3 months periods for distribution subsidy calculation in Indonesia (*): losses regulation is coherent with DSO operational and accounting cycle
- 8 years period in UK (**): regulation rules are fixed in coherence with DSO investment cycle on losses

Question	≤ 1 year	3 years	4 years	5 years	8 years
Are these constraints / incentives based on a periodic cycle? If yes, what is the period?	2 (*)	3	3	2	1 (**)

Table 4: Survey question on regulatory periodic cycle

Losses volume regulation

In a majority of countries, the regulation for losses is global (Table 5). In other countries, the regulation allows for a differentiation between TL and NTL, with some specific definitions (for example, in Japan, NTL costs are not recovered). One DSO in Brazil underlines that, even if the regulation for losses is global, the difference between TL and NTL management exists in fact: TL are inherent in the distribution process and NTL come from human action or process failure.

Question	Yes	No
From a legal and regulation standpoint, are there differences between TL and NTL management?	5	10

Table 5: Survey question on TL/NTL regulatory management

All DSOs communicate information on losses to a regulator or public authorities (Table 6). This corresponds in general to the value of global losses, which are rarely detailed between TL and NTL. In countries where NTL is neglected (Austria, Finland and Japan for example), this corresponds to the value of TL.

Question	Global	With detail TL - NTL	Only TL (*)	No
How do you have to communicate your losses? Is it the same for TL and NTL?	12	1	3	0

Table 6: Survey question on communication about losses

Losses price regulation

Losses are priced based on market prices for a majority of DSOs, but other DSOs have specific loss tariffs (Table 7). Japan is a particular case where generation sources are used to compensate for losses. There is no general rule between type of actor (DSO vs supplier) and type of price (market price vs tariff).

Question	Market price	Tariff	Other (Generation)
Q8. What is the price for TL and NTL?	8	4	1

Table 7: Survey question on price for TL and NTL

Future evolutions

In a majority of the countries, regulation is not the only reason for losses reduction. Such efforts are also motivated by cost reduction and/or energy efficiency (Table 8).

Question	Cost reduction	Energy Efficiency	No other reason
Is there any other reason impacting your willingness to tackle losses?	6	4	4

Table 8: Survey question on reasons to tackle losses

In European countries (*: only European respondents), the main direct impact that the said Directive may have on DSO processes concerns national regulation (Cf. Energy Audit by ENEA in Italy and possible evolution of Czech regulation) or on long term objectives (with more metering and losses attention expected in Sweden).

Question	Impact	No impact	No answer
If relevant, what has been (or will be) the impact of the European Energy Efficiency Directive (Art.15.2) on your process to tackle losses?	3	4	7 (*)

Table 9: Survey question on European Energy Efficiency Directive

The opinion expressed predominantly by DSOs is a growing concern on losses management (Table 10). The main given reasons are AMI projects, some network investment (low losses transformers, new SCADA or DAS), a “meter-to-cash process” optimization in Portugal (a holistic approach to the revenue value chain and NTL reduction, including metering and analytics), and potential impact of DG on losses levels for one European DSO. Furthermore, a “stable” evolution in the losses management is often considered by DSOs who are already highly involved in loss mitigation (e.g. in Brazil).

Question	Increase	Decrease	Equal
How do you see the evolution in the losses management when comparing the last 5 years and the future? Why?	10	1	5

Table 10: Survey question on evolution of losses

Analysis of Survey Responses on Regulation

Regulation is an integral part of the management of losses, and is one of the contributing factors to the reduction of losses, along with cost reduction and concerns over energy efficiency. This part of the report helped identify the current state of regulation in different countries with respect to losses. This was done through the analysis of responses to a survey conducted by the working group.

In the future, it should be possible to better identify the key questions regarding the roles of different actors on losses, the perimeter of regulation and the duration of regulation cycles. The current situation with respect to these questions is heterogeneous and unclear, with contrasting answers received for the survey.

6.3. ANALYSIS ON LOSSES REGULATION

6.3.1. Theoretical regulation models

Different theoretical models may be considered for regulation of distribution cost in general and losses in particular:

- 1 Cost recovery model: tariffs cover the totality of network costs and include a margin for the DSO, calculated as a % of ROI.
- 2 Cap regulation model: DSO Tariffs are defined ex ante for the period and each DSO has to challenge its specific given level. The DSO may have higher or lower margin depending on its effective results.
- 3 Beat yourself (output based): real losses in the network of each DSO during the last regulatory period are compared with their own losses during the previous period (it is an adaptation of cap regulation model).
- 4 Yardstick model: global tariffs are defined ex ante for all DSOs on a common mean value, whatever their initial level of losses, and DSOs have to challenge the given level.

Thus, distribution losses characteristics are specific to each DSO network and highly depend on global regulation scheme in each country. Therefore, the application of theoretical regulation models to distribution losses requires a preliminary analysis and a relevant adaptation, as illustrated in some European countries (Table 11):

Model	Cost recovery	Cap regulation	Beat yourself (output based)	Yardstick
Examples	Belgium, France, Germany	UK (new regulation)	Spain (from 2014)	Italy, Spain (until 2014)
Application to losses regulation	Preliminary step to learn on “efficient” level and uncertainties evaluation for losses	Only if expected gain greater than uncertainties (measurement, risks)	Only with a majority of DSOs already efficient in losses management Otherwise, this model would benefit inefficient DSOs (with much room to improve).	A necessary adaptation to specificities and variability of losses

Table 11: comparison of regulation models for distribution losses

The choice of a regulation method and the definition of its key parameters (threshold, cycle duration ...) highly depend on the situation of each DSO in front of losses: estimated losses volume and rate, losses factors identification, possibility to manage and forecast ...

6.3.2. Possible regulation schemes

Two different regulation schemes may apply to losses according to how they are defined:

1. Regulation to control the evolution of losses as a whole (Cf. Level 1 losses definition).
2. Regulation to focus on specific sources of losses (Cf. Level 2 and 3 losses definition).

We now propose a global analysis of each regulation scheme.

I. Regulation to control the evolution of losses as a whole

Where an electricity market exists, the regulation scheme depends on who buys the energy for the losses. This is described in Table 12:

Who buys losses	Risk for the actor who buys losses	Possible regulation
DSO	DSO is directly exposed to : <ul style="list-style-type: none"> • Evolution of loss volumes • Market price • Effects in their own price due to loss forecasting 	DSOs are allowed to recover the cost related to procure their losses in the market. There are two different approaches: <ul style="list-style-type: none"> ○ <u>Pass-through approach</u>: revenues related to the procurement of losses are calculated as a pass-through. In this case, incentives/penalties should be also implemented in order to incentivize losses reduction. (Cf. infra) ○ <u>Competitive approach</u>: revenues related to the procurement of losses are calculated using a yardstick model (e.g. considering the amount of energy losses related to the amount of delivered energy, the price obtained, etc.)
Supplier	Suppliers are exposed to every kWh of losses of a network that cannot be controlled by them. ⇒ DSO shall cover supplier risk: isolate correctly the supplier from an eventual increase of the losses volumes	DSOs are encouraged to promote an efficient management of losses using an incentives/penalties based on: <ul style="list-style-type: none"> ○ Evolution of losses in the system as a whole; and/or ○ Evolution of losses per DSO. Calculation of the incentive/penalty for each DSO can be based on: <ul style="list-style-type: none"> ○ <u>Benchmarking</u>: considering outcomes from other DSOs. ○ <u>Per DSO</u>: not considering outcomes from other DSOs.

Table 12: Regulation scheme depending on who buys the energy for the losses

We can identify that different systems exist for purchasing losses (integrated company, DSO, or supplier) according to the prevailing situation and regulatory choices.

These specificities may have a major impact on definition of losses and on their measurement process.

II. Regulation to focus on specific sources of losses

Here are in Table 13 some examples of regulation incentives that aims to lower the cost of mitigation of losses:

Approach	TL	NTL
Awards related to improving efficiency	X	X
R&D efforts	XX	XX
Mitigation means	X	XX
Smart-meter with automatic identification and meter "handling" (big data IT, analytics, optimized process)	X	XXX
DSO keeps part of losses gain	X (investments)	XX (fraud)
Incentive on price of losses	X	

Table 13: Regulation incentives aiming to lower the cost of mitigation of losses

The efficiency of regulatory incentives depends on the created value:

- A better knowledge and control on TL / NTL (X): possibility to have more focused mitigation actions.
- Optimized mitigation actions on TL / NTL (XX): better TL/NTL control and detection at lower cost.
- A break-through in losses mitigation (XXX): new optimized processes, high control on network and meter dysfunctions.

III. Comparison of regulation schemes

The following table 14 compares the two approaches proposed for losses regulation:

Approach	Type of situation	Incentive / DSO	Key point
Control losses evolution as a whole (level 1 losses definition)	High losses level	Increase revenue	Political agreement DSO losses strategy
Focus on losses sources (levels 2 and 3 losses definition)	Low losses level and/or Low uncertainties level	Process efficiency (ROI + Quality of service)	Measurement accuracy Relevant incentives / mitigation actions

Table 14: Comparison of approaches proposed for losses regulation (global vs detailed)

The scenario with a **control on losses evolution as a whole** consists of giving DSOs a global incentive on losses volumes (and prices), which means:

- Sufficient losses volumes to make losses strategy profitable.
- A political agreement on DSO losses strategy (e.g. billing acceptance).

The scenario with a **focus on losses sources** consists in having a sufficient view on:

- Measurement accuracy compared with losses gain and uncertainties (e.g. DG impact, climate hazard).
- Coherency between regulation and DSO action plan strategy (relevant incentives according to quantified losses mitigation actions).

IV. Actor in charge of losses

Different systems may exist (Integrated, DSO, Supplier) according to prevailing situation in a given country and regulatory choices made in it. Any given system has not proved to be better than the others. However, some good practices across systems can be noticed:

- The transparency on loss level and sources, according to a common definition for losses as proposed in the report (cf 2.4):
 - o A global understanding of the mitigation objectives and actions, with a necessary cooperation between actors (Cf. metering data sharing between supplier and DSO for datamining approaches in the UK).
- Relevant regulation adapted to the level and structure of losses:
 - o Technical losses : take into account network specificities and uncertainties (climate hazard, DG location).
 - o Non-technical losses : take into account DSO global environment (e.g. country economic situation and metering strategy, especially for smart-meters).

6.4. CONCLUSION

Regulation does not create value or reduce losses by itself : It is an ingredient of a quite an elaborate recipe that has to take into account the specificities of each DSO situation on with respect to the network structure, operational processes, and more globally, the economic and social and economic environment.

However, some key factors can be underlined as a result of the work leading to this report:

- The transparency on levels and sources of losses, according to a common definition as proposed in the report.
- A global understanding of losses mitigation objectives and actions, which implies a necessary cooperation between actors.
- A Relevant regulation fit to losses level and structure.

The report has also identified some good practices for regulation of losses:

- The need of a preliminary study before defining a global strategy and an action plan, especially for choosing between a global regulation on losses (volumes and prices) and a more specific approach.
- The definition of a relevant regulatory scenario with adapted parameters (period, ratio, incentives, ...), which should be realistic, quantifiable, compatible with market rules, and preferably distinguished between TL and NTL.
- A long-term view on losses, with a coherency with investment valorisation (with a relevant ROI) and a limited impact of losses inherent variability (with a suitable regulation period).

The economic decisions of a DSO, in general, encompass many other factors apart from losses. However, losses have to be part of the equation, either as a cost that is leveraged (when the decision helps reducing losses) or as a cost that is borne (in all other cases). Consequently, regulation has a major role in guiding and facilitating choices, not in penalizing or “punishing” a DSO. If regulation does have to “punish” DSOs, it should do so only for short periods and only with justifiable reasons. For example, regulation may help develop new efficient ways for mitigating losses, with new measurement systems such as pre-paid or smart meters.

In the global sense, loss regulation should always consider the views of all concerned stakeholders, be it for mitigating energy theft, reducing distribution bills, or for increasing energy efficiency.

In this point of view, regulation of losses can be seen :

- Inside DSOs, as a key decision factor for global economic decisions and process optimization.
- Outside DSOs, as a way for measuring, controlling, and optimizing electric flows, considering their cost for the global electric system.

7. APPENDIXES

7.1. APPENDIX ON TECHNICAL LOSSES

Introduction

This appendix lists examples of different TL types and details experiences on mitigation of TL.

All the information mentioned below in appendix are in reduced version (quotations) of papers and documents, with some comments in italic.

Assessing the impact of photovoltaic self-consumption support policies on energy losses [16]

The number of photovoltaic (PV) self-consumption installations has grown strongly due to cost reductions. PV self-consumption installations have an influence on the value of energy losses in the network. The paper analyzes the energy losses (fixed and variable technical losses) produced by PV self-consumption in the region of Murcia (Spain) (*) for two different regulatory frameworks: instantaneous self-consumption (ISC) and net-metering (NM). These regulatory frameworks will have an impact in the design conditions and dimensions of future PV self-consumption installations. Therefore, the impact on energy losses of each regulatory framework will be different. In the case of ISC, prosumers do not have any economic return when the excess of PV energy is injected in the network. Therefore, PV self-consumption installation must be dimensioned to minimize payback time. Thus, PV self-consumption installation is designed to provide 40% of the annual energy demand of the prosumer. Conversely, in a NM scenario, prosumers dimension their PV installation in order to cover 100% of their energy needs. The PV self-consumption adoption level is the number of customers with PV self-consumption installation versus the total number of customers and is considered in steps of 10%. Energy losses are calculated for a year using detailed hourly calculations for eight representative days: one working day and one holiday for each season. The three different voltage levels (HV, MV and LV) have been analyzed separately [16].

(*) : a specific case of high Consumption – Generation synchronism (cooling system / PV Generators).

When a PV self-consumption installation is designed under an ISC scheme (fig.17), PV installed power is minimized as well as the exports to the network, that is, the installation maximizes the self-consumption rate. As it can be seen in the (fig.18), energy losses are reduced in all voltage levels. The maximum reduction is achieved for 100% adoption level [16].

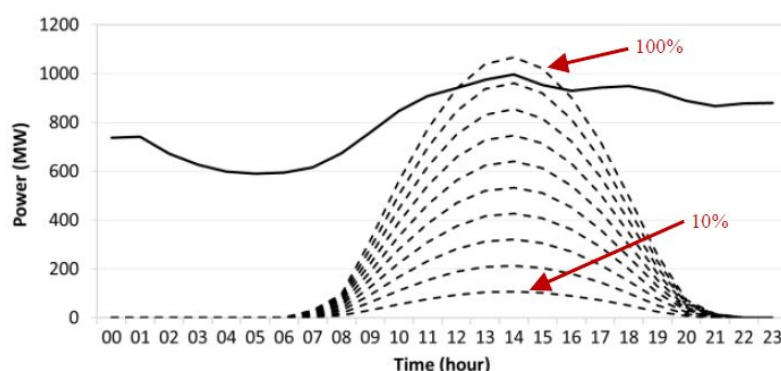

Figure 17: Load demand (July) versus PV generation for different adoption levels (ISC case) [16]

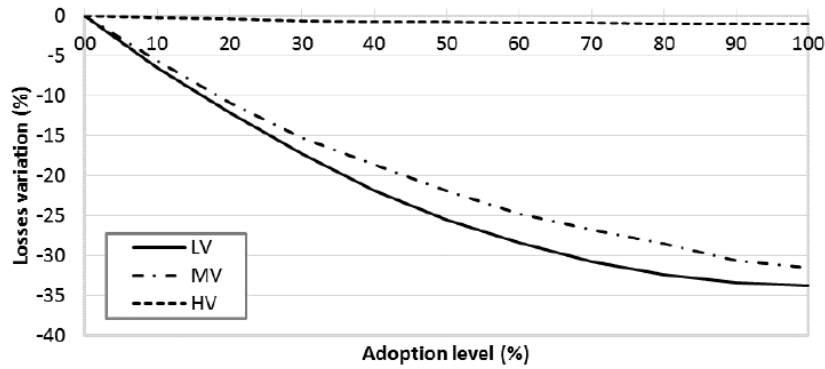

Figure 18 Variation of energy losses for the ISC case as a function of adoption level [16]

When PV self-consumption installations are designed under a net-metering scheme (fig. 19), the maximum PV power generation could exceed substantially the load demand. Either in winter or summer, PV peak power could be more than two times the total energy demand at midday if all customers adopt self-consumption. With a NM scheme, there is a turning point in energy losses located at around 40% of PV self-consumption adoption level and when PV adoption level achieves a value higher than 80%.then losses are higher than energy losses in the base case (fig.20) [16].

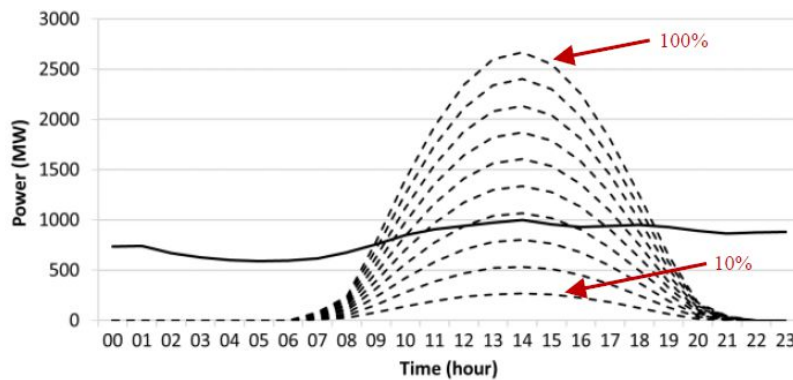

Figure 19: Load demand (July) versus PV generation for different adoption levels (NM case) [16]

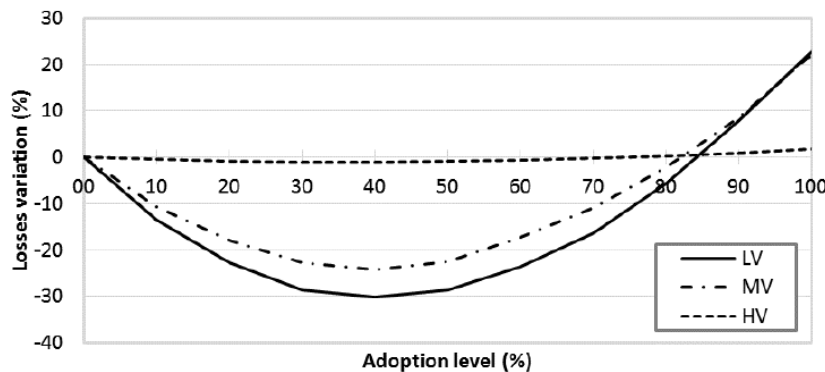

Figure 20: Variation of energy losses for the NM case as a function of adoption level [16]

Conclusion :

These results largely depends on the context of this case analysis in Spain, but confirm two main factors:

1. Regulatory framework on photovoltaic self-consumption will impact the dimensions of future PV self-consumption installations and therefore the energy losses.
2. In the Murcia context (good synchronism between consumption and PV-generation), ISC regulation leads to reduce losses where NM regulation could increase losses on large adoption level.

Variable renewable energy sources integration in electricity systems 2016 - How to get it right [24]

Example from Italy shows interesting information about seasonal and daily effects of sun variation on the power generation of a small PV plant in central Italy (Figure 21). In paper [24] is possible to find similar illustration about effects wind variability in Ireland on the global wind fleet power production and more information about critical success factors and extracts practical solutions for success on the field of variable renewables integration in electricity systems.

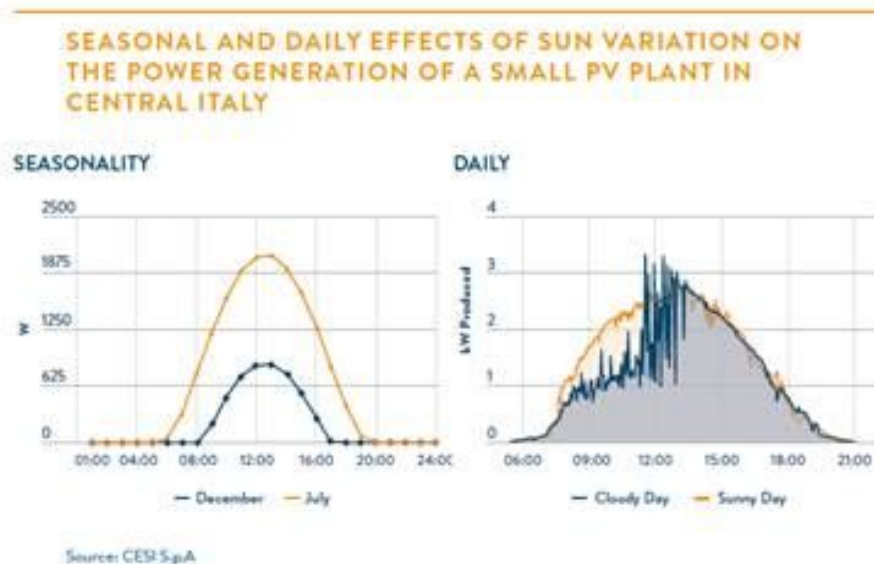

Figure 21: Illustration of PV seasonal and daily variability in Italy [24]

Project LODIS (Local Optimization of Distribution grids) [23]

Interesting idea was tested in Czech Republic in project LODIS (Local Optimization of Distribution grids). Is possible local LV overproduction of PV managed by on demand switching of boilers with using prediction of production PV? Figure 22 shows the algorithm with aim to find optimal tariff switching plans for tomorrow for each consumption point according to expected production and consumption at given location.

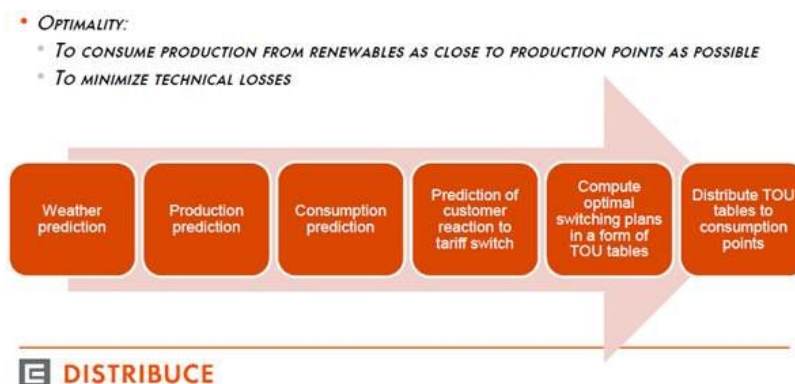

Figure 22: Algorithm of LODIS project [23]

LODIS project tested hypothesis, that we can utilize data from Smart metering for Smart grid world with real actions and real benefits.

Cost benefit analysis of MV reactive power management and active power curtailment [19]

Active power curtailment

Active power curtailment of DG connected to MV networks is another alternative solution to grid reinforcement which is studied for assessing its feasibility and its economic interest. This solution (Figure 23) is based on limited power curtailment to avoid technical constraints when necessary. This solution can be interesting when constraints appear only a few hours per year. In these cases, it is economically more relevant to reduce power injected by DG during these few hours than to reinforce the network [19].

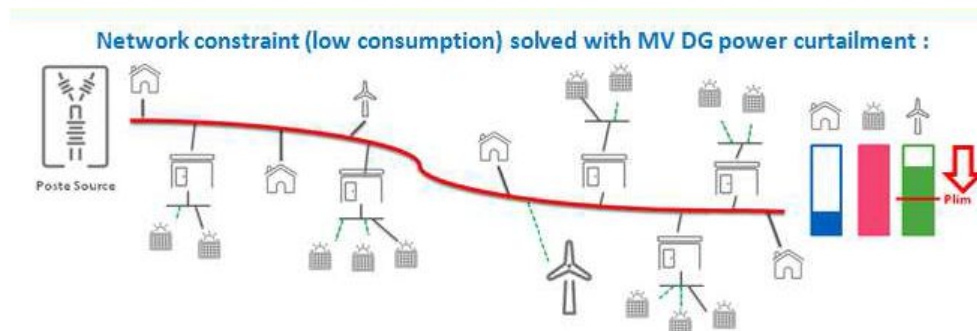

Figure 23: Active power curtailment principle [19]

It is illustration of the importance of geographical proximity and time synchronism between local production and consumption for losses control.

Self-adaptive reactive power regulation

For analysing the self-adaptive reactive power regulation, the study focuses on the reduction of reinforcement that can be done with extended DG reactive power capabilities solving voltage constraints if the DG is connected to an existing MV feeder. The self-adaptive reactive power regulation has also an impact on the annual level of network losses compared to the regulation with a fixed ratio between reactive and active power. (Figure 24) The two benefits, reduction of connection costs and network losses, must then be compared to the implementation cost of this smart grid solution (self-adaptive reactive power regulation).

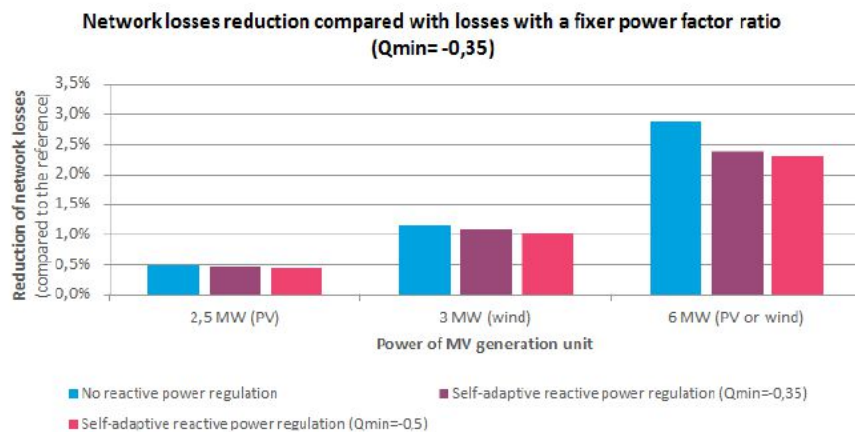

Figure 24: Network losses reduction with self-adaptive reactive power regulation [19]

Authors are of opinion, that a potential reduction of connection costs is between 90 k€/MW and 100 k€/MW when these solutions solve constraints and are cost-effective compared to network reinforcement [19].

Causes of technical losses [10]

- Inefficient equipments such as transformers
- Inadequate size of conductor in the distribution lines.
- Long distribution lines.
- Load imbalance among the phases.
- Low power factor.
- Over loading of lines.
- Transformers installed far from the load centers.
- Haphazard installation of distribution systems to cope with demands to new areas.
- Bad workmanship [10].

Using capacitors [12]

One of the main benefits of applying capacitors is that they can reduce distribution line losses. Losses come from current through the resistance of conductors. Some of that current transmits real power, but some flows to supply reactive power. Reactive power provides magnetizing for motors and other inductive loads. Reactive power does not spin kWh meters and performs no useful work, but it must be supplied. Engineers widely use the “2/3 rule” for sizing and placing capacitors to optimally reduce losses. Figure 25 shows the loss reduction for one fixed capacitor on a circuit with a uniform load. The 2/3 rule specifies that the optimum distance is 2/3 of the distance from the substation and 2/3 of the circuit’s var requirement. As long as the size and location are somewhat close (within 10%), the not-quite-optimal capacitor placement provides almost as much loss reduction as the optimal placement [12].

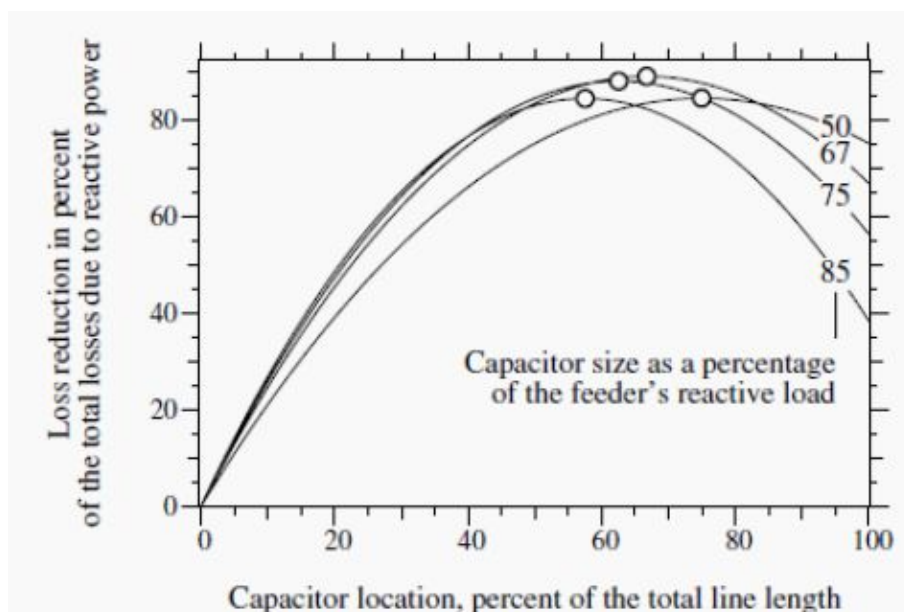

Figure 25: Sensitivity to losses of sizing and placing one capacitor on a circuit with a uniform load. (The circles mark the optimum location for each of the sizes shown) [12]

First use of smart grid data in distribution network planning [20]

The historical model uses billing data and statistical profiles to project the behaviour of customers and estimate currents and voltages all over LV grids during peak conditions. Besides, phase connection of single phase customers remain unknown. LV network design since the system has to be designed considering new equipments and behaviours: PV generators, voltage regulation, electric vehicles, storage devices and demand response. If not well-handled, these new functions can increase losses, degrade quality, damage equipments or on the contrary lead to over-investments. The ERABLE project led to a new calculation tool for LV networks design based on AMM data, individual load curves and real phase connections. The main challenge is managing the quantity of data: a very large number of customers, with each one its load/generation characteristics for every considered day [20].

Results of Phase-Balancing Study Case [20]:

This network contains 4 LV feeders. The blue feeder presents phase unbalance as detected by the developed (ERABLE prototype) system. The ERABLE phase-balancing tool has though been run on this network. It proposes only one "smart" phase-switching: a single-phase customer connected close to the end of the feeder has to be moved from phase 1 to phase 2 [Figure 26].

Pictures below in left column before balancing and in right column after balancing.

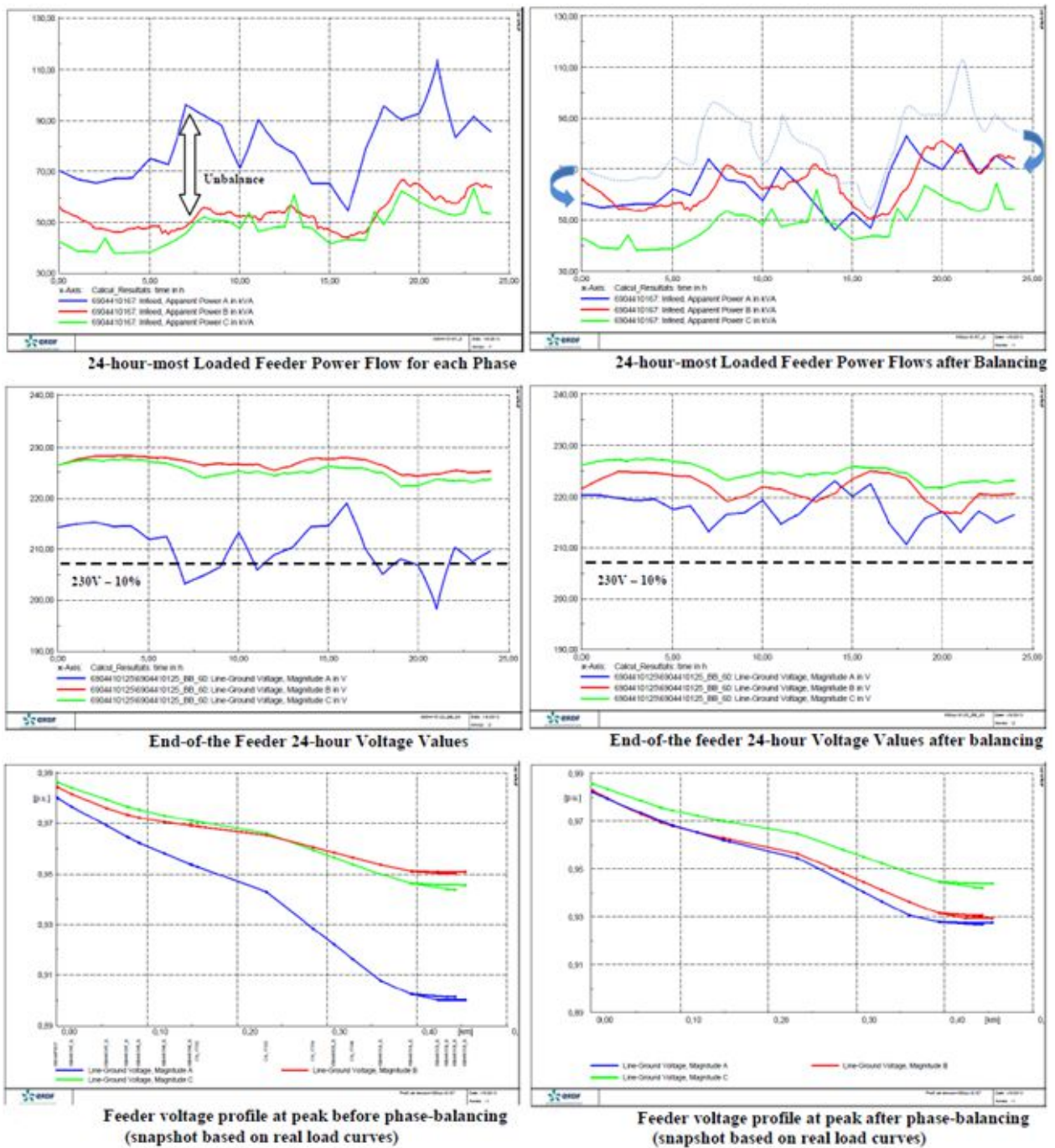

Figure 26: Results of Phase-Balancing Study Case [20]

Figure 26 shows successful elimination of unbalance and improvement of voltage profile at peak.

Economically, the 2.6% voltage drop reduction avoids or differs network reinforcements representing about 20 k€ and a 10-year 1 k€ losses reduction (10 years NPV) [20].

Cut costs, losses with transformer technology upgrades [11]

Modern transformer technology is capable of reducing transformer losses considerably.

“No load” or “fixed” losses are present as soon as the transformer is energized. “Load losses” vary according to the load on the transformer. Distribution and power transformers run 24 hours a day, therefore their energy efficiency can be impacted by reductions in both “no load losses” and “load losses”. For utilities, it may be more advantageous to reduce iron losses than copper losses, since the transformers are energized 8760 hours a year. These transformers typically do not supply load during this entire period and when they do supply load, it is never at the maximum load capacity. On the other hand it may be advantageous for industrial applications to reduce the “load losses”, as these transformers are operated mainly at high load factor. A0, B0 C0, D0, E0 no load loss categories are defined in EN 50464, “European standardization for transformer losses reduction”. Comparisons are made among conventional GOES (grain oriented electrical steels), new GOES, and Amorphous transformers (Figure 27) in the A0 category [11].

Rated power	Technology	No load losses level	Load losses level	No load losses (W)	No load losses reduction
400kVA/Oil immersed	Conventional GOES	A0	C_k : 4600W	430	0%
400kVA/Oil immersed	New GOES	A0+	C_k : 4600W	300	30%
400kVA/Oil immersed	Amorphous	A0++	C_k : 4600W	<200 (160)	63%

Figure 27: Loss comparisons of conventional, New GOES, and amorphous transformers [11]

European standard for distribution transformers losses is in Figure 28

No-Load (Iron) Losses		Load (Copper) losses	
Level	Gains over E_0	Level	Gains over D_k
A_0 : 430W	54%	A_k : 3,250W	46%
B_0 : 520W	44%	B_k : 3,850W	36%
C_0 : 610W	34%	C_k : 4,600W	23%
D_0 : 750W	19%	D_k : 6,000W	-
E_0 : 930W	-	-	-

Figure 28: European standard for distribution transformers losses [22]

Own Energy Consumption of Smart Metering Infrastructure (SMI) and Energy Monitoring Systems (EMS) [15]

With respect to smart metering, the task findings indicate that the general awareness on the issue of own energy consumption of SMI is still low. Relevant and valid data from the project shows that the meter itself contributes between 76% and 98% to the system-wide average input power per metering point (due to the fact other SMI equipments are largely mutualized between metering points). The meter properties and technical features, as well as the system conditions especially for communication of meter data are the main drivers influencing the overall own energy consumption of the SMI. In this sense, the communication technology takes up a key role and as such has been used as the main feature to distinguish between systems [15].

Figure 29 shows a schematic arrangement of devices for SMI and EMS, the boundary in between and the overlapping area where the internet provides online reporting.

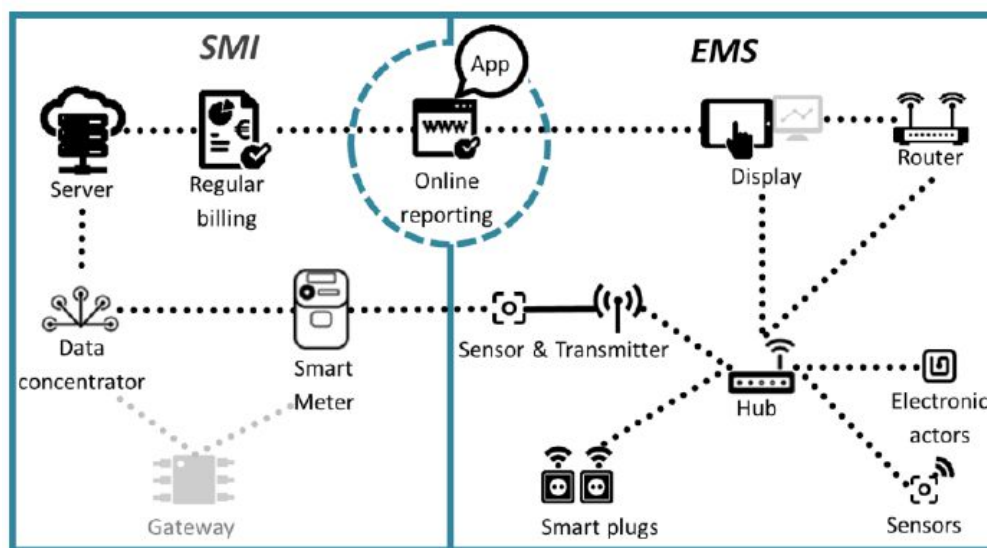

Figure 29: Simplified graphical depiction of the boundary between SMI and EMS [15]

Concerning SMI, the advanced meter is proved to have lower consumptions than a classical meter in most cases (except A_1 scenario). It implies that new data services do not require more energy consumption per metering point. In some cases the replacement of a park of “classical” meter by a park of smart meter on a DSO perimeter globally contributes to a reduction of technical losses, especially with new generations of meters which prove to have even lower individual consumptions than these presented in study [15].

In case of EMS, the own energy consumptions can be substantial, especially for energy management systems with a large number of connected nodes (i.e., smart plugs), adding up to 101.5 kWh of annual electricity consumption per household, in one of the scenarios [15].

IPC contribution to LV network efficiency and reliability [13]

International and national standards for IPC (Insulation Piercing Connectors) are a strong basis to secure safety and reliability over time. However, no current standard is seriously considering how efficient LV connectors are or could be. LV IPC connectors have their own resistance and do contribute to the overall LV network efficiency (Figure 30). While the actual resistance of an LV connector may seem insignificant, it turns out that there can be very wide discrepancy in the overall resistance of LV connectors. LV connector efficiency becomes significant when considering the millions of connectors installed on any network and the fact that every kWh reaching any meter shall flow through 4 or more of these connectors [13].

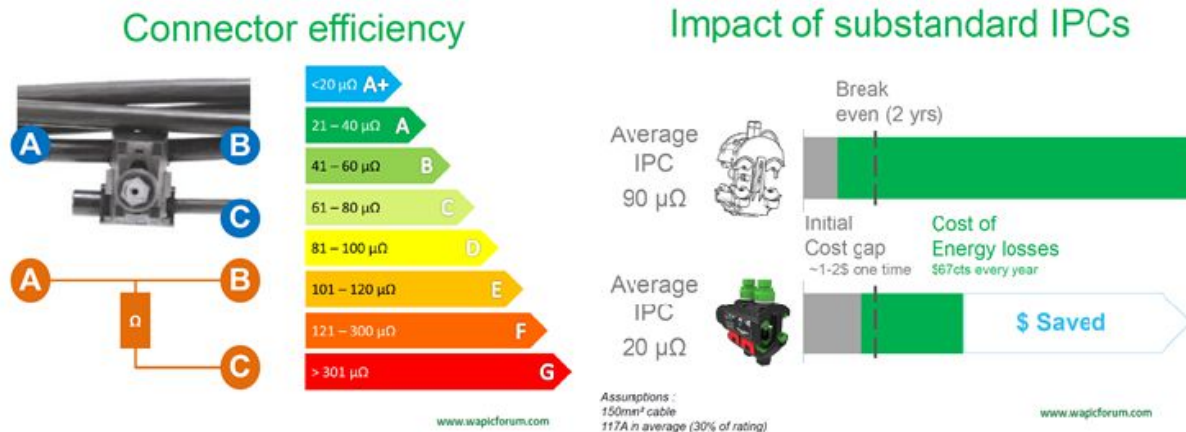

Figure 30: Efficiency scale proposal for LV IPCs [13]

Evaluating Efficiency and Losses of Various Circuit Protective Devices [14]

Devices with lower internal resistance will have less power loss compared with devices having a higher internal resistance [14]. Figure 31 and Figure 32 show some comparison for different protective devices.

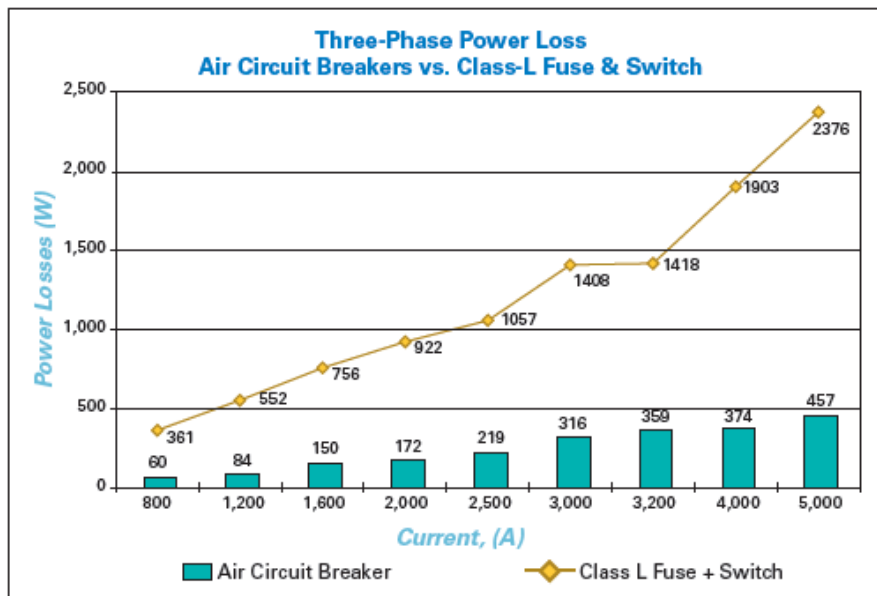

Figure 31: Power loss comparison – Air Circuit Breaker vs Class L Fuse & Switch [14]

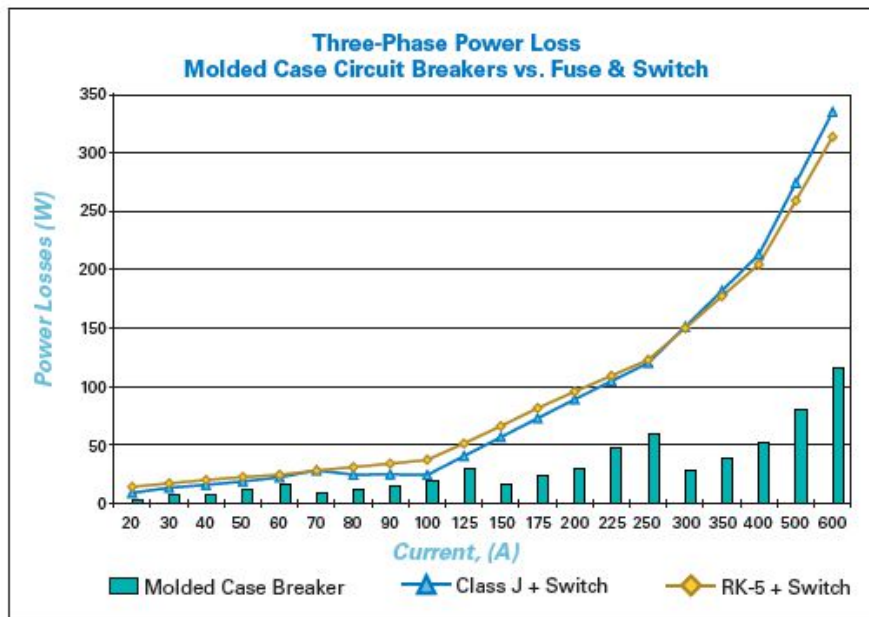

Figure 32: Power loss comparison – Molded Case Circuit Breakers vs Class J & Class RK-5 Fuse & Switch [14]

Extra energy consumed by a device must be purchased from some source to feed additional device losses. Reducing those extra device losses means less power must be purchased. If a more efficient device is used, the less energy wasted also means less energy is generated at the source [14].

How to reduce power losses in distribution lines [10]

Losses in the distribution of electricity cannot be eliminated, but can be minimized by proper planning of the distribution systems to ensure that power remain within limits. Some of the ways to reduce losses include:

- Use of proper jointing techniques, and keeping the number of the joints to a minimum.
- Regular inspection of the connections, isolators, drop out fuses, LT switches, transformers, transformer bushing-stem, and other distribution equipment.
- Proper selection of conductor size, as well as the transformer in terms of efficiency, size and location (taking into account MV transformers are designed considering contingencies situations). In particular, it is important to locate the distribution transformers at the load center and if possible keep the number to a minimum.
- Feeding heavy consumers directly from the feeders.
- Maintain the network components and replace those that are deteriorating, worn out or faulty.
- Proper load management and load balancing.
- Use of electronic meters which are accurate and tamper-proof.
- Improving power factor by adding shunt capacitors [10].

7.2. APPENDIX ON NON-TECHNICAL LOSSES

7.2.1. MORE DETAIL AROUND NTL TYPES AND EXTENT

Types of NTL

Electricity theft is listed by several sources as a significant contributor to NTL⁵. The estimated total global annual losses due to electricity theft are more than \$25 billion, of which \$4.5 billion occur in India [Depuru 2011]⁶.

Measurement, accounting and information errors are listed in several other references⁷.

Unmetered supplies (including unmetered auxiliary services and unmetered own consumption) are also listed frequently as sources of NTL⁸.

Time difference between meter readings and period of calculation refers to energy usage estimations that have to be made when losses are calculated for a defined period (e.g. a month or a year) but the meter readings for the end date (e.g. 31st Dec 24h00) or for the start date (e.g. 1st Jan 00h00) are not available.

Size and types of losses in Europe

In Europe, excluding the UK, NTL include theft, non-registered consumption, own consumption, non-metered supplies such as public lighting and errors in metering, billing and data processing (including time lags between meter readings and statistical calculation) [ERGEG 2008].

Total distribution losses range from 2.3% (Sweden) to 11.8% (Poland), with Romania being an outlier at 13.5% [ERGEG 1]. 19% of energy used in Turkey is illegal [Cavdar 2004]⁹.

Some new Member States have much higher losses at the distribution level than the other Member States; possible reasons include the condition of the networks and higher-than-average amount of NTL, e.g. from unmetered consumption, metering errors and theft [ERGEG 2008].

References quoted in [Smith 2004] state that a utility in Budapest estimates annual losses due to theft to be 6.5%.

In Spain 35% to 45% of NTL are estimated to be due to fraud [Monedero 2011].

One village in Romania experienced 84% of total supplied energy not being billed; after implementation of mitigation measures this was reduced to 26.1% (9.7% of which were TL) [Harabagiu 2005].

One utility in the UK [SPEN 2014] lists the types of NTL it has encountered as illegal connections, meter tampering/bypassing (by a minority of customers), unmetered supplies that are incorrectly or inaccurately estimated and billing errors due to incorrect recording of consumption. Total losses in its networks were estimated to be 5.8% to 6.0% in 2009-10.

⁵ Examples are [Antman 2009], [ERGEG 2008], [SPEN 2014], [ENW 2015], [SSEPD 2015], [WPD 2015], [Monedero 2011], [Nagi 2009], [Bastos 2009], [Beutel 2015], [News 2016-03] and [News 2016-08].

⁶ Referenced from an Indian government website that is no longer available.

⁷ [Antman 2009], [ERGEG 2008], [SPEN 2014], [ENW 2015], [SSEPD 2015], [Nagi 2009], [Bastos 2009] and [Agha 2016], amongst others.

⁸ [Antman 2009], [ERGEG 2008], [SPEN 2014], [ENW 2015], [SSEPD 2015], [WPD 2015], [Monedero 2011] and [Nagi 2009], amongst others.

⁹ Referenced in [Pasdar 2007].

Another UK utility [ENW 2015] mentions bypassing or otherwise tampering with meters to avoid paying the high electricity costs associated with the heat lamps used to produce cannabis as a concern for DSOs in the UK.

A third UK utility [SSEPD 2015] identifies the case where there is no registered supplier at a connection point as an additional source of NTL. Total losses on their distribution systems are about 6% to 9%.

Western Power Distribution in the UK [WPD 2015] reports that about 6000 cases per year of "illegal abstraction" (meter tampering, bypassing etc.) occur, of which about 1000 relate to cannabis production.

The regulator in the UK [OFGEM 2015] estimates that total T&D losses in the UK were 7.2% in 2013, of which most (about 73%) were technical losses on the distribution system. NTL on the distribution system were about 4% of the total losses (or 0.27% of energy supplied to the transmission system).

Size and types of losses in Central and North America

References quoted in [Smith 2004] state that electricity theft by illegal connections to the network are widely prevalent in parts of Mexico, with losses reported to be \$475 million annually. This figure is confirmed by [News 2002]. Marijuana use also drives electricity theft in Canada [News 2010-10] and the USA [Depuru 2011].

A study in Arizona [Culwell 2001]¹⁰ found a probable meter tamper rate of 1% and annual losses to the utility of \$7,967,279, with the majority of losses occurring from commercial customers. Electricity theft and theft of equipment from the electricity network costs about \$6 billion per year in the USA [News 2013-02].

Bureaucratic processes are reported as preventing people from applying for legal connections in Mexico [News 2002].

Size and types of losses in South America

The following is known about Brazil:

- In 2006, the Brazilian electric sector lost 15.3% of its internal energy supply; NTL alone may surpass 25% in some cases [Bastos 2009]¹¹.
- Another estimate is that 7.3% of the energy supplied to distribution systems is lost to NTL, at a cost of about \$ 1.76 billion annually [Barioni 2015].
- The biggest components of NTL obtained from a case study of one area are (starting with the highest) are fraud, errors in metering and faulty equipment, illegal reconnection by ex-consumers.

Size and types of losses in Asia

China and Vietnam generally have relatively low levels of losses [Antman 2009], but no details are available.

Urban cooperatives in the Philippines do not operate as efficiently as they could, but the private utilities operate reasonably well [Antman 2009]. Malaysia's privatised electricity T&D system and Thailand's public system both have total T&D losses of about 11% [Smith 2004].

¹⁰ Quoted by [Smith 2004].

¹¹ From another document referenced in [Bastos 2009].

Total losses exceed 30% in Pakistan [Antman 2009]. Total losses exceed 20% in Bangladesh [Antman 2009]. [Transparency 1999]¹² estimates a loss of 14% due to NTL in Bangladesh in 1998-99. A utility in Indonesia estimated theft losses to be 7% [Smith 2004].

Power utilities PEA of Thailand and TNB in Malaysia consider electricity theft to be the major source of NTLs, the majority of which involve meter tampering or vandalism or illegal connections [Nagi 2009]. NTLs are estimated to be around 15% on the Malaysian peninsular [Nagi 2009].

[Nagi 2009] also reports that:

- Tampering is by breaking the meter's housing seal for tampering with the components inside. Once this is accomplished the spinning disc is mechanically obstructed or the numbers that the meter readers use are turned back (this method is obviously not applicable for digital display meters).
- Illegal connections to LV power lines (220V single-phase systems) occur mainly in shanty towns and other residential districts and by small businesses and street vendors
- Other types of NTL include inaccurate, inadequate or faulty metering, inaccurate billing, other types of fraud such as collusion with utility personnel, non-reporting of faulty meters and inaccurate estimation of non-metered supplies.

Electricity usage is not charged for in certain countries to certain pre-allocated groups of consumers, e.g. the residence of the president or prime minister or employees of the electricity utility such as the 32,000 employees of the Electricity Generating Authority of Thailand (EGAT) who receive free electricity worth 1.5 billion baht (around \$42.8 million) [Smith 2004].

In 2004, TNB in Malaysia estimated a loss of \$229 million per year due to NTL, not only theft [Chauhan 2015].

The following is known about India:

- Average total transmission and distribution losses have been officially stated as 23% of the electricity generated, but has been estimated to be up to 58% in at least one case [Monedero 2011].
- More specifically, total transmission and distribution were approximately 15% up to 1966-67, but increased gradually to 28.36 % by 2011-12 [Navani 2012].
- The two private utilities supplying Mumbai have total losses of 11-12%, most of the state utilities have losses of over 30% [Antman 2009].
- The effects of restructuring have not always been positive when it comes to losses [Monedero 2011]:
 - Before restructuring Orissa reported 23% total T&D losses, after restructuring they were 51%.
 - In Andhra Pradesh these losses were about 25% before restructuring about 45% afterwards.
 - Haryana's losses went from 32% to 40%.
 - Rajasthan's losses increased from 26% to 43%.
- Types of NTL are illegal connections; meter tampering/bypassing and errors in equipment; unmetered supplies to agricultural pumps with larger loads than originally paid for; single point connections to small low-income domestic consumers; estimation of consumption where no meters are installed [Monedero 2011].
- Total distribution and peak distribution loss collected from a field survey in a mixed urban and rural area in Ghaziabad district were found to be 27.45 % and 34.2 % respectively [Navani 2012].

The former Soviet Union has high total losses and poor revenue collection rates, due to weak metering, billing and payment collection in the 1980s; this has not changed in Russia and some other former Soviet countries [Antman 2009].

¹² Quoted in [Smith 2004].

Size and types of losses in Africa and the Middle East

In Sub-Saharan Africa only 50% of electricity is paid for due to, amongst other reasons, a large amount of consumed energy not being billed [Antman 2009]. Botswana's stated-owned utility is the best performing utility in the region, with system losses of 10% [Antman 2009].

The following is known about NTL in South Africa:

- As much as 7% of electrical energy produced in South Africa is lost to theft [News 2014-12].
- Types of NTL include meter bypassing or tampering and illegal connections to the network [Beutel 2015]. The latter have resulted in deaths, often children, due to the dangerous manner in which they are carried out [News 2015-01], [News 2015-02], [News 2015-03].
- The reliance on human resources for reading meters means that when there are staff shortages, electricity cannot be billed. As an example, meters could not be read in King William's Town for about 6 months at the time of writing, resulting in a revenue loss of more than R2.4 million [News 2016-05].
- 52% of business customers of Eskom, the country's largest utility, have been found to bypass their meters [News 2016-03].

Senegal [Guymard 2013]:

- 21% of the produced energy is lost without being sold.
- The distribution between TL and NTL (the latter mostly fraud) is unknown in the distribution grid.
- The spread of distribution technical losses between the 30 kV, 6.6 kV and 400V grids is also unknown.
- NTL represent 40 billion FCFA (\approx \$70 million), presumably per annum.
- Meters are in short supply, making it impossible to control new connections and to replace defective meters.
- Own consumption is not known in some buildings since they are not metered.

Uganda loses almost \$29.6 million annually due to electricity theft [News 2016-08].

Types of NTL in Jordan are CT and VT accuracy errors, meter accuracy errors, meter failure, billing errors (shifting period errors – differences in meter reading dates – and human errors), energy theft [Agha 2016]. Total distribution losses in NEPCO (Jordan) in 2014 were 13.79%, an increase from 12.29% in 2011. Total T&D losses were 14.33% in 2014 [NEPCO 2014].

An Iranian paper states that theft is the largest component of NTL, e.g. illegal connections onto the network, meter bypassing or tampering and evading payment. The former is the most common form of NTL [Hosseini 2015].

7.2.2. MITIGATION OF NTL

Introduction

This appendix first lists experiences on mitigation of NTL per region, then detail measures or experiences not linked to particular regions or countries, with a focus on central check/observer meters (a commonly proposed measure also known as “energy balancing”) and data mining/analysis.

Mitigation of NTL in the UK

Methods presently used to reduce NTLs in the UK include¹³:

- Targeted inspections and audits, including auditing of unmetered supplies and updating records to ensure accuracy of the estimates.
- Perform investigations systematically e.g. investigate parties who applied for connections but didn't complete the process, or to ensure that energy theft isn't repeated where it was previously identified.
- Responding to leads from stakeholders.
- Implementing a team of staff to identify parts of the network that produce the highest technical or non-technical losses and implement mitigation measures.
- Actively performing risk assessments and determine trends and hotspots.
- Identify tampering or bypassing when installing smart meters.
- Use network (especially at secondary substations) and smart customer metering to identify areas with high levels of NTLs and/or individual customers with suspicious consumption behaviour.
- Improve accuracy of records for unmetered supplies.
- Normalizing or repairing tampered installations and other equipment.
- Addressing unrecorded energy by updating information systems with more accurate consumption data.
- Cooperating with enforcement agencies, pursuing prosecution, social services and storing evidence.
- Liaison with other stakeholders in the industry.
- Providing appropriate training and awareness.
- Updating records to reduce billing errors.
- External engagement around best practice.

Revenue protection is seen as a key aspect of the strategy, e.g. updating of records; stakeholder engagement and knowledge sharing to improve processes and systems; development and use of a theft risk assessment tool; engages and assists with respect to prosecution of offenders; conducts internal and external awareness programs [SPEN 2015].

Inaccuracies around estimation of NTL are to be addressed via increased or improved measurements on and modelling of the network, e.g. using smart meters and monitoring of secondary substations [SPEN 2014].

There are limitations with the present losses estimation method since it is not time-based, but smart meters (which are expected to be installed by the end 2020) should increase the accuracy to +/- 1.5% [OFGEM 2015].

The UK has a maximum sentence of 5 years for electricity theft [UKRPA 2015].

Future industry drivers in the UK include more accurate measurement of losses (e.g. via smart meters), hence stricter incentive schemes for reduction of losses like in some other countries [ENW 2015]. Secondary substation monitoring (for technical loss reduction but could also be used for detection of NTLs) and detection of the presence of cannabis heat lamps are also being investigated [OFGEM 2015].

¹³ Obtained from [SPEN 2014], [SPEN 2015], [ENW 2015], [OFGEM 2015], [SSEPD 2015].

One UK DSO is actively investigating smart meters coupled with substation metering to detect areas with high losses [SSEPD 2015].

Mitigation of NTL in the remainder of Europe

To date there have been no formal attempts to harmonize the treatment of network losses at a pan-European level. The majority of European countries broadly account for physical losses, thefts and metering errors in their regulation. The objectives of the regulatory treatment of losses are to protect the interest of customers and to promote the efficiency of the network [ERGEG 2008]. It is considered that improvements in metering will improve the evaluation of losses in distribution networks; it is therefore suggested that more metering points are implemented and that losses are taken into account in the cost/benefit analysis of new metering equipment. However, measuring non-technical losses is very expensive, often more expensive than the value of the lost energy [ERGEG 2009].

Methods for analyzing losses should be simple, transparent, predictable and reasonably cost reflective and should allow for losses to be monitored so that comparisons (improvements or otherwise) can be made over time. Some respondents suggest that specific non-technical losses that can be estimated (like public lighting) should be isolated and treated accordingly. TL are difficult to reduce in the short term due to the long life of plant, but NTL may be more amenable to reduction by increased attention to theft prevention and to the data acquisition procedures. NTL can be reduced by incentives designed to reduce theft, improve metering and reduce unmetered supplies. However, reducing total losses may be a better option in practice due to the difficulties in separately measuring TL and NTL. The most effective NTL reduction measures may well vary between member states as the conditions vary between these countries [ERGEG 2009].

A Spanish study that involves detecting anomalous drops in consumed energy (reportedly the most frequent sign of a theft or tampering by a customer) by using windowed analysis and the Pearson coefficient is reported in [Monedero 2011] and [Guerrero 2013]. Usually mitigation is presently via physical inspections of customers chosen from consumption studies (labour intensive) or customers with zero consumption over a certain period (this only catches very obvious theft). The algorithms developed in this study use only consumption data from the previous two years and have been tested with real (large) customers, and the system has been put into operation. 38% of the customers flagged via these methods were found to have NTL, which is better than the 10% obtained by routine inspections. An automated system was developed for detection of NTLs on company databases; it uses all information available, not just consumption data, e.g. data mining, statistical techniques, text mining, neural networks and expert systems, in order to classify a customer problem as accurately as possible. 40.66% of customers flagged using the automated system had NTLs, at 90% less time spent than traditional methods. So far this method has only been used for large customers.

The Spanish DSO Iberdrola (as a Prime Alliance member) has implemented power line carrier (PLC) technology between smart customer meters and secondary substations which have supervisory meters on the secondary side of each MV/LV transformer. The customer and supervisory hourly values of their meters are sent from the secondary substations to a central system with regular communication. This allows balancing between customer energy usage and energy supplied by the secondary substations to be performed, which in turn allows secondary substations with high losses to be identified for inspection and determination of the cause of the losses. These kinds of inspection directed at areas with high losses have in most cases uncovered high rates of fraud due to illegal connections to the grid (buried underground or behind walls). Refer to section 7.8 for further information on energy balancing.

Iberdrola is also working on an innovation project with advanced supervisory meters on each line of the secondary substation with Ariadna Instruments S.L. These meters have higher supervisory capabilities than normal, such as recording the load curve with per-second resolution. This advanced supervision allows the identification of connectivity errors (differences between the connection of a customer in the field and data base information), meter tampering detection and power quality reports. This kind of report compares the advanced supervision load per second with the highest load values of the customers. The

result of this advanced supervision shows a 100% success rate in identifying meter tampering and connectivity problems.

[Guerrero 2013] also reports that many advanced techniques have been used by other researchers for detecting NTL, examples are listed below (these methods are not necessarily used only in Europe):

- Detection rules where a series of data mining tasks are compounded.
- A system based on a non-supervised artificial neural network.
- Use of Naïve Bayesian or Decision Tree algorithms.
- Support Vector Machines which can be combined with other computational intelligence such as fuzzy inference systems or genetic algorithms.
- Differential evolution algorithms.
- Rough sets.
- Feature selection.
- Statistical analysis.
- Fuzzy clustering.
- Euclidean distance.
- Various methods of profiling customer loads using smart meter data or otherwise using smart grids.

Most countries from the former Soviet Union who joined the EU have successfully privatized their DSOs – the implication is that their losses have reduced, but this is not explicitly stated [Antman 2009].

The measures applied in the Romanian village [Harabagiu 2005] included:

- Reduction of the average number of consumers per transformer point to reduce the number of disconnected consumers for unpaid bills or other reasons.
- Reducing the length of LV feeders, i.e. lengthening MV feeders.
- Meters located in the distribution box of the transformer point.
- Remote meter reading system.
- Replacement of transformers with lower power ratings, each equipped with automatic safety switches for each consumer and a 3-phase circuit breaker with overload and short-circuit protection.

Some utilities in Eastern Europe provide incentives for staff for collection of revenue [Suriyamongkol 2002].

Mitigation of NTL in Malaysia [Nagi 2009]

In Malaysia, TNB has adopted 3 main measures to minimize and work towards preventing NTLs:

- Installation of a Remote Meter Reading (RMR) service to provide power consumption statistics and online billed data for HV clients.
- Installation of a prepayment metering system and physical protection of metering installations for high voltage high risk customers (HRCs).
- Setting up of a “Special Enforcement Against Losses” (SEAL) team to investigate problems by conducting onsite customer meter installation inspections on LV commercial domestic and light industry customers and hence to reduce and minimize NTL problems faced by TNB. The SEAL team’s activities include improving metering and billing processes, ensuring metering is accurate, and reducing the theft of electricity. The team was set up in 2004 and by 2005 distribution losses had been reduced by about 1%.

Further information from TNB is as follows:

- The electricity theft rate for TNB in 2005 was reduced by almost 50%, where the theft rate for large customers (LPCs) was reduced from 3% to 1.5% and for ordinary customers (OPCs) the theft rate was reduced from 4.1% to 2%.
- In 2006 additional engineers, technicians and meter readers were specifically trained to spot billing consumption irregularities. New equipment was also procured and transportation was provided, in order to pursue suspected cases of power theft, which were overlooked in the previous years.

- The SEAL team aggressively carried out various activities including improvement of the customer billing process, conducting physical meter inspections, testing and rectification of the metering systems for LPCs and certain numbers of the OPCs; these efforts resulted in substantial amounts of back billing and collections.
- Additionally, the SEAL team installed secure meter boxes for HRCs and (ii) Expanded Metal Protection Doors (EMPDs) for OPCs, in order to prevent from meter tampering.

TNB also expanded their “Enhanced Customer Information Billing System” (e-CIBS) in 2006, in order to identify HRCs for better security against power theft; the e-CIBS provides the SEAL team with accurate analysis and consumption reports, which can identify consumption patterns of repeated power theft.

In 2007 and 2008, large inspection campaigns were carried out by the SEAL team including meter checking and premise inspection, reporting on irregularities and monitoring of unbilled accounts, meter reading and sales. However, this had little success due to newer and improved methods of electricity theft, which are difficult to identify, and customer installation being inspections carried out without any specific focus or direction – most inspections are carried out at random, while some targeted raids are undertaken based on information reported by the public or meter readers.

The study presented by [Nagi 2009] proposes a method to overcome such limitations by monitoring and detecting deviations in customers’ load profiles (i.e. fraud), as an alternative to complement the ongoing existing actions enforced by power utilities to reduce NTLs. The fundamental approaches are:

- An unsupervised approach for determining outliers with no prior knowledge of the data using unsupervised clustering.
- Semi-supervised modeling only normality, or in a few cases modeling abnormality, using semi-supervised recognition or detection.
- Supervised modeling of both normality and abnormality using supervised classification with pre-labeled data.

The three broad machine learning approaches mentioned use the following major outlier detection methods: statistical-based methods, distance-based methods, density-based methods, clustering-based methods, deviation-based methods. The method was found to result in an improvement in the detection of fraud, e.g. in 2005:

- Without the use of a fraud detection system the average hit-rate was 3-5%.
- With the use of the effective fraud detection system the hit-rate increased 38%.

Comparison of models:

- Standard Support Vector Classification (SVC): 32% hit-rate.
- SVC and Fuzzy Inference System (FIS) model: 40%.
- In some Malaysian cities where the combined SVC and FIS system was tested a hit-rate of up to 48% was achieved.

Mitigation of NTL in India

Some state-owned utilities that were privatized reduced losses significantly through business efficiency improvements such as the introduction of “state-of-the-art management and information technology tools” [Antman 2009].

However, privatization is not necessary to reduce losses. The Andhra Pradesh State Electricity Board (APSEB) restructured into separate generation, transmission and distribution units, while keeping state ownership, resulted in transmission and distribution losses being reduced from about 38% in 1999 to 26% in 2003 and less than 20% in 2008. A major portion of this resulted from reduction of theft (including illegal connections to the power system and tampering with or bypassing meters, often with the assistance of utility staff) by [Antman 2009]:

- Acknowledging the problem;

- Estimating its size via energy audits;
- Enacting strict laws against electricity theft;
- Establishing dedicated enforcement and prosecution mechanisms;
- Improving efficiencies including advanced and tamper-proof meters, remote meter reading and IT systems;
- Enclosing transformers;
- Normalizing 2.25 million illegal connections;
- A comprehensive communication program and close monitoring of progress.

North Delhi Power Limited (NDPL) reduced total losses of 53% when it was founded in 2002 as a public/private partnership to 15% in 2009, by implementation of advanced metering infrastructure (AMI) for the customers responsible for most of the revenue (considered the most successful measure), use of MV networks in theft-prone areas, replacement of meters, energy audits, improved enforcement, involvement of the community, education around safety and appropriate regulatory incentives [Antman 2009].

Awareness programs in India resulted in drop in total transmission and distribution losses from 38.86% in 2001-2002 to 34.54% in 2005-2006 [Depuru 2011]¹⁴.

Other methods used to reduce NTLs include [Navani 2012]:

- Upgrading of electricity meters to meet standard accuracy (including statistical analysis);
- Smart card technology (to minimize the theft of energy);
- Integrated billing system and prepaid energy meters;
- Technical training to the operating personnel (and enhance employees loyalty to eliminate pilferage in the distribution system);
- Statistical monitoring of energy consumption per sector, class and geographical setup (and statistical evaluation of meter readings).

Mitigation of NTL in Latin America

In Latin America losses were often larger than 30% in the 1980s. Utilities that privatized in the 1980s and 1990s produced substantial reductions in TL and NTL through improved efficiency. Measures included electrification of previously unelectrified areas, but this aspect was not always successful (in Chile, for example, it was successful). Chile also assisted utilities in other countries in the region to successfully privatize. The utility Chilectra Metropolitana has losses of about 5%, reduced from 22% [Antman 2009].

Enersis (various utilities owned by the same company) achieved a significant reduction in losses by normalization of illegal and unmetered customers, improved efficiencies, stepped-up maintenance, customer communication around payment and safety, tamper-proofing meters, training and monitoring of contractors, enforcement and prosecution. Over half of the non-technical losses addressed resulted in reduced demand. There was also effective but fair regulation [Antman 2009].

In the 1990s El Salvador, Guatemala, Panama and Nicaragua created a completely new regulatory framework for their power industries, which included unbundling, open transmission access and privatization of the distribution business. The experience of the El Salvadorian utility DELSUR in improving customer care and response and implementing advanced IT systems resulted in the total losses more than halving in 5 years (2002-2007) [Antman 2009].

Brazil privatized almost half of their DSOs in the second half of the 1990s, almost all of them took advantage of the regulated loss targets. The Brazilian utility CEMIG is an example of a state-owned utility that has performed similarly well. In Buenos Aires 655,000 low-income users were successfully

¹⁴ Referenced from the same Indian government website that is no longer available.

normalized by the two local private utilities and appropriately incentivized by the government. AMI has been very effective in detecting and discouraging bypassing, tampering, collusion and other unmetered consumption in developing countries such as the Dominican Republic, Honduras and Brazil [Antman 2009].

MV distribution with shielded connections and split meters is used in parts of Rio de Janeiro state where access is difficult. Each customer must have a dedicated low capacity MV-LV transformer (ideally) or at least a direct connection to the transformer. This together with having the meter in a sealed container at the transformer makes undetected illegal connections very difficult. Installing meters at transformers supplying more than one customer is recommended for fast detection of theft [Antman 2009].

A small number of LPCs, often supplied at medium and high voltage and usually representing less than 1% of the total number of customers, represent more than 30% of a DSO's revenue. These customers should be fully billed, monitored and, if necessary, normalized on a continuous basis. Many utilities in Latin America have achieved this by sound business efficiency and use of appropriate IT systems. A dedicated customer service department for dealing with LPCs, including speedy resolution of problems, is critical as it reduced the incentive to bypass or tamper. In some parts of Brazil the utility is not allowed access to its metering equipment on the customer's premises, a second meter has been installed outside the premises [Antman 2009].

[Antman 2009] further states that "comprehensive experience in almost all Latin American reforming countries show that consumer discipline is achieved in quite a short time if those irregular consumers become aware that the utility is able to make fast detection and take corrective action on fraud and theft".

ELEVAL (a utility in Valencia, Venezuela) has developed a tool for detecting and locating concealed illegal connections to underground cables [Parra 2006], once their presence has been established via use of a check meter. The amount of NTL established in this way is then used to prioritize networks for inspection. The tool involves locating unauthorized underground connections via high frequency injection, reducing the amount of digging required – time by more than 50% and cost by more than 80%.

Split meters with the meters in boxes with tamper detection are also used in Brazil [Ribeiro 2012]. Utilities in Brazil may by law retrospectively charge customers for stolen energy up to 6 months by estimating the energy that was used [Barioni 2015].

Bayesian networks are explored in [Bastos 2009] using real Brazilian data.

A method based on the application of unbalanced weighted least squares state estimation and anomaly detection is used to estimate and identify TL and NTL is suggested by [Rossoni 2015]. The method was successfully implemented in a laboratory environment where the behaviour of typical Brazilian consumers was modelled. The method was also applied on an actual Brazilian distribution network; with promising results.

Mitigation of NTL in Africa

Split meters are being rolled out in parts of South Africa [News 2016-07]. This makes it more difficult to bypass, or otherwise tamper with, the meter, since it is no longer located inside the consumer's premises.

According to radio reports on the 9th and 10th of May 2016, Johannesburg's municipal electricity provider, City Power, has appointed contractors to check every electricity meter for illegal connections. A new dedicated unit will also be established within the organisation to deal with management of meters.

Other initiatives deployed successfully in South Africa are removal of illegal connections, conducting meter audits and correcting or replacing faulty or vandalised meters [Eskom 2016].

Another (extreme) tactic is to deal with illegal connections is to disconnect power in an entire affected area [News 2015-03] (for safety reasons in this case), but this can result in anger from those disconnected.

Methods to reduce NTL in Senegal are recommended to include industrial meter safety checks and meter roll-out outside of residential premises, measuring device roll-out on each LV feeder, comparison between the network energy flow measurements and the sum of clients billing statements of the supplied zone would easily flag zones where fraud is most widespread, targeting controls on these zones for a better efficiency. The installation and controlled reading of meters is an important part of this [Guymard 2013]. Whether any of these have been implemented and, if so, the success rate is not known.

A CIRED paper from Egypt [Emara 2013] reports on an approach based on a genetic algorithm with multi-objective optimization analysis, management of electricity distribution network planning includes, in addition to load flow and voltage profile analyses, power delivery quality assessments, operation reliability analyses and, above all, economic evaluation of all investments. The method does not appear to have been implemented at the time of publishing of this paper.

Comments not related to specific countries or regions

General comments

When users who previously did not pay for electricity then have to pay, their demand usually decreases, resulting in a decrease also in technical losses [Antman 2009].

NTL also result in increased TL due to the additional current that is drawn [Suriyamongkol 2002].

Privatized distribution utilities show 11% lower distribution losses, 32% more electricity sold per worker and 45% greater bill collection rate than state-owned utilities (achieved within five or more years of being privatized). However, the regulatory framework must be present to support privatized utilities, especially setting realistic loss targets where utilities keep the profit if they beat targets but suffer a loss if they don't (this worked well in several Latin American countries) [Antman 2009].

A disproportionately high portion of losses tend to emanate from users that require the largest amount of electricity, so tackling these first has been successful in emerging economies; these losses have been known to include collusion by utility employees. "Naming and shaming" such large customers, usually well-known companies, has also been successful, as has successfully and visibly prosecuting politically-connected energy thieves [Antman 2009].

Since most criminals are not aware of the fraud detection methods that have been successful in the past, they will adopt strategies which will more likely lead to identifiable frauds; therefore to detect fraud earlier detection tools need to be applied as well as the latest developments [Nagi 2009].

Factors that influence electricity theft include belief that stealing from utilities is not wrong or illegal, difficult economic times, lack of education, lack of law enforcement, corruption of utility employees (by deliberately reading lower consumption values for example), certain areas not electrified and high (or believed to be high) energy prices [Depuru 2011].

A mitigation measure proposed by [Depuru 2011] is to charge a lower tariff for low income customers to make theft less attractive. Other methods cited by the same reference from various sources are smart meters (which are stated as being difficult to tamper with), power line impedance measurements, use of shunts detecting equipment to detect unauthorized connections and use of check meters.

Mitigation methods listed by [Smith 2004] include technical/engineering methods, e.g. tamer-proof meters, managerial methods, e.g. regular inspection and/or monitoring focussing on users with the

highest usage (cf. poor areas that use comparatively little power), tackling of corrupt employees and system change, e.g. public v. private utilities, regulation, who pays for losses etc. Privatisation does not automatically or necessarily result in a more efficient business, and a multi-method approach is recommended.

Software has been developed that has shown good results in producing optimised strategies for dealing with electricity theft by deployment of AMR and manual inspection [Ribeiro 2012].

Another type of NTL is the willful hacking and modification of smart meter usage data via cyber-attack, which is becoming more and more of a risk due to the data-intensive nature of smart grids [Leite 2016]. Cyber-attacks may be targeted at any part of the system, e.g. at the meter itself or at the communication system or at the data values themselves [Jokar 2016]. Privacy of customer information should be considered in any method that uses customer usage data [Jokar 2016]. An advanced method for detecting and locating such attacks is also given in [Leite 2016], but the method has not been implemented in the field as yet.

Comments related to specific technologies

Prepaid AMI also has advantages of much lower hardware costs and the ability to permanently monitor consumption over card-based prepaid systems [Antman 2009].

Time domain reflectometry (TDR) may be used to localize sources of NTL [Trupinic 2005] – the premise is that the reflected pulse shape is different if an illegal or tampered connection is connected to if only meters are connected to a feeder. This method can be used for very precise local research once suspicion is established. The method has been tested in a limited way, but does not appear to have been implemented at the time of publishing of this paper.

TDR is also proposed for use in detecting NTL by [Hossein 2015], to complement analysis of data. The method works by sending a pulse down a cable to detect any changes in cable impedance. Events such as change of cable type, broken cable or fault will result in a change in impedance can in principle be detected, but tests with a commercially available TDR instrument showed that the results require careful examination.

[Depuru 2011] proposes a smart system where illegal customers (those with >5% NTL) are identified, paying customers are then disconnected, the system is then subjected to a voltage high in harmonics that destroys appliances connected to the system and finally paying customers are re-connected again. This system has several practical hurdles, including protecting system components from damage due to the harmonics, public resistance, cost of roll-out, and the efficiency of detection of legal and illegal customers. Also, the legal framework may not be in place in all countries.

Minimising the length of the LV network is proposed for Turkey by [Yorukoglu 2016] (the original idea is from one of the references in that document). It is also proposed that meters are installed at the top of poles (out of reach). Only supplying power to agricultural areas during certain times of the day is also proposed (the idea for this is from one of the references citing the practice in India). This would require separation of agricultural networks from other networks in the areas under consideration.

Using armoured cables makes connecting illegally onto them more difficult [Ribeiro 2012].

A proposed method of reducing illegal connections to the network is to raise the voltage to a level that would damage normal electrical equipment (say 350 V on a 230 V system) and step it down to its normal level at each consumer [Babu 2013]. This would also reduce technical losses on the LV network, but the method has not, to the author's knowledge, been trialed in the field.

Placing all meters in an area (presumably a relatively small area) in the same enclosure on the street makes detecting of bypassing by inspection much easier [Bandim 2003].

The use of unmanned aerial vehicles is suggested for assistance with detecting electricity theft once smart grid technologies have been used to determine the general location of such theft [Rengaraju 2014].

Central check/observer/supervisory meters

This is a method that has been suggested by several sources as a way of detecting NTL, and is therefore covered in a separate section here. It is also known as “energy balancing” and involves some form of checking that the energy that is recorded as being consumed by the customers on a network is the same as the total energy that is supplied to that network, i.e. checking that there is are not unmetered or undetected loads connected to the network.

The following details are amongst those available:

- The Spanish DSO Iberdrola (as Prime Alliance member) has implemented power line carrier (PLC) technology between smart customer meters and secondary substations which have supervisory meters on the secondary side of each MV/LV transformer. Iberdrola is also working on an innovation project with advanced supervisory meters on each line of the secondary substation. These meters have higher supervisory capabilities than normal, such as recording the load curve with per-second resolution. Both projects have resulted in significant successes, further details may be found in Section 7.3. Mobile check meters, left in place for at least a month, are proposed as a way of doing this with lower costs – real customer data was used to verify this [Doorduyn 2004].
- This method can be used to determine any type of NTL, not just theft [Bandim 2003]. This ref uses mathematical methods to identify customers with problems and/or a high probability of bypassing, focusing inspections to only those premises. This has not, to the author’s knowledge, been trialed or otherwise implemented in the field.
- An extended version of this is proposed whereby the current is measured at every pole on an overhead LV feeder, and the values compared [Chauhan 2015]. This has not, to the author’s knowledge, been trialed or otherwise implemented in the field.
- Another variation of the method where customer consumption is compared to a central observer meter is covered in [Jokar 2016]. The method was tested on real customer data.
- The theft detection rate at ENEL (Italy) increased from 5% to 50% after check meters were installed at 5% of supply points of delivery to compare with the power usage of the customer meters [Lu 2013].
- A method for detecting NTL whereby the current is measured at various points on the network is proposed by [Beutel 2015], but has as yet been implemented. Smart customer meters are included, as well as a meter at the secondary substation. This is similar to the proposals of [Bandim 2003] and [Santos 2015].
- A method for determining which customer is connected illegally, once the presence of an illegal connection has been established, using power line carrier is proposed in [Pasdar 2007]. The method has not been implemented, to the best of the author’s knowledge.
- A variation without smart meters is proposed in [Ilo 2003], but does not appear to have been implemented at the time of publishing of this paper.
- The principle is also stated in [Navani 2012] and [Emara 2013].
- [Berrisford 2013] found a value of C\$732 million in rolling out smart meters at BC Hydro for revenue protection alone. The main part of this strategy is energy balancing. The method is described and includes correlation between and non-linear optimisation of the customer voltages (and energy usage). The method is also able to detect high resistance joints on the service connection, as well as network data or topology errors. Initial results are promising.

The use of central check or observer meters would likely need to be part of a wider “smart DSO” system, such as that discussed in Europe [EDSO 2016], and would allow more frequent and localized checking of energy balance. This would allow for faster detection and more accurate location of NTL than in a “traditional DSO” and with less manual intervention. A “smart DSO” would also involve greater business efficiency generally, theoretically resulting in reduced risk of metering or billing errors.

Data mining/analysis

According to [Gemignani 2009] it is possible to statistically pre-identify fraudsters through load and demand factor comparison. The concept revolves around having a typical load/demand factor profile for each profile of consumer. Assuming this profile is regularly updated, it becomes possible to identify the behaviour of some meters against these profiles. The calculations of the load and demand factors have been carried through for the residential, commercial and industrial classes, but the method does not appear to have been implemented at the time of publishing of this paper.

Detection of physical tampering already exists in smart meters, e.g. sensors for change in inclination (bumping) and removal of the cover, but can give false positives. An advanced data-analysis method of detecting energy theft, while minimizing false positives, is presented. It looks promising but has not yet been rolled out [McLaughlin 2013].

Mathematical methods for detecting NTL (specifically theft) can be state-based, or classification-based or use game theory – several references of such methods are given in [Jokar 2016].

Some statistical/data techniques for detecting theft are referenced in [Chauhan 2013].

A state estimation method using smart meter data is proposed for detection of NTL [Lu 2013].

An example of a data-analysis method using consumption profiles is given in [Angelos 2011], the method was validated on real data but has not as yet been implemented.

A method for speeding up consumption data analysis is given in [Depuru 2013].

Another method for using analysis of consumption data is given in [Mashima 2012].

8. REFERENCES

NB: the numbering of references is specific for each section

8.1. REFERENCES ON DEFINITION PART

[1] Treatment of Losses by Network Operators; ERGEG Position Paper for public consultation; 15 July 2008

Treatment of Losses by Network Operators; ERGEG Position Paper; Conclusions Paper; 19 February 2009

[2] Losses Strategy; Electricity North West; June 2015

[3] SSEPD RIIO-ED1 Losses Strategy; Scottish & Southern Energy Power Distribution; April 2015

[4] Study on tariff design for distribution systems – Final Report; AF-Mercados, Ref-E, Indra; 11 December 2014

[5] An Intelligent System For Detection Of Non-Technical Losses In Tenaga Nasional Berhad (TNB) Malaysia Low Voltage Distribution Network; Jawad Nagi; 2009

[6] Identifying Energy Efficiency improvements and saving potential in energy networks, including analysis of the value of demand response; Tractebel Engineering, Ecofys; 18 December 2015

[7] Distribution Loss of Electricity and Influence of Energy Flows: A Case Study of a Major Section in Kerala; P. R. Suresh, Shanavas Elachola; September 2000

[8] Losses Strategy; SP Energy Networks; September 2015

[9] Energy Efficiency Directive: An assessment of the energy efficiency potential of Great Britain's gas and electricity infrastructure; OFGEM; 16 June 2015

[10] <http://electrical-engineering-portal.com/total-losses-in-power-distribution-and-transmission-lines-1>

[11] A Case Study of Analysis of Technical and Non Technical Losses in Power System and its Impact on Power Sector; J.P Navani, N.K Sharma, Sonal Sapra; 2012

[12] Reducing Technical and Non-Technical Losses in the Power Sector; Background Paper for the World Bank Group Energy Sector Strategy; July 2009

[13] Detection of frauds and other non-technical losses in a power utility using Pearson coefficient, Bayesian networks and decision trees; Inigo Monedero, Felix Biscarri, Carlos Leon, Juan I. Guerrero, Jesus Biscarri, Rocio Millan; December 2011

[14] Transmission and Distribution Losses (Power); M S Bhalla; 2000

[15] Non Technical Losses – How do other countries tackle the problem?; Ron Millard, Mike Emmerton; 2009

8.2. REFERENCES ON MEASUREMENT PART

[1] Treatment of Losses by Network Operators; ERGEG Position Paper for public consultation; 15 July 2008

[2] Dynamic load profiling; Enedis ; CIRED 2013.

[3] Project PERFILA ; REE 2015; <http://www.ree.es/en/red21/rdi/rdi-projects/perfila>

8.3. REFERENCES ON TL PART

[1] Energy Efficiency Directive

Available: <https://ec.europa.eu/energy/en/topics/energy-efficiency/energy-efficiency-directive>

[2] Energy Efficiency Directive

Available: <http://eur-lex.europa.eu/legal-content/EN/TXT/PDF/?uri=CELEX:32012L0027&from=EN>

[3] Treatment of losses by network operators – Conclusions Paper Ref: E08-ENM-04-03c

Available:

<https://www.ceer.eu/documents/104400/-/-/6f455336-d8c8-aa6f-36d3-fe5264caf57d>

[4] Available: <http://data.worldbank.org/indicator/EG.ELC.LOSS.ZS>

[5] 2009 - ERDF Experience in reducing network losses
/Michel ODDI, Frédéric GORGETTE, Guillaume ROUPIOZ/

Available: http://www.cired.net/publications/cired2009/pdfs/CIRED2009_0520_Paper.pdf

[6] Analysis of distribution losses and life cycle CO2 emissions

/Martin ATEN, Robert FERRIS

http://www.cired.net/publications/cired2009/pdfs/CIRED2009_0560_Paper.pdf

[7] Identifying Energy Efficiency improvements and saving potential in energy networks, including analysis of the value of demand response, in support of the implementation of article 15 of the energy efficiency directive (2012/27/EU)

/Tractebel Engineering, Ecofys 2015 by order of: European Commission/

Available:

https://ec.europa.eu/energy/sites/ener/files/documents/GRIDEE_4NT_364174_000_01_TOTALDOC%20-%2018-1-2016.pdf

[8] Available:

http://eng.kurzy.cz/commodities/index.asp?SEO=electricity&A=5&idk=142&od=29.9.2003&curr=EUR&default_curr=EUR&unit=1%20MWh&lg=2

[9] Detailed analysis of network losses in a million customer distribution grid with high penetration of distributed generation

/Wolfram HECKMANN, Lucas HAMANN, Martin BRAUN, Heike BARTH, Johannes DASENBROCK, Chenjie MA, Thorsten REIMANN, Alexander SCHEIDLER/

Available: http://www.cired.net/publications/cired2013/pdfs/CIRED2013_1478_final.pdf

[10] Available: <http://engineering.electrical-equipment.org/electrical-distribution/power-losses-in-distribution-lines.html>

[11] How Utility Electrical Distribution Networks can Save Energy in the Smart Grid Era

/Michel CLEMENCE, Renzo COCCIONI, Alain GLATIGNY/ Available: http://download.schneider-electric.com/files?p_enDocType=White+Paper&p_File_Id=1724847349&p_File_Name=998-2095-11-25-13AR0.pdf&p_Reference=998-2095-11-25-13AR0_EN

[12] Reducing Distribution Line Losses - Using capacitors
/Edvard CSANYI/

Available: <http://electrical-engineering-portal.com/reducing-distribution-line-losses>

[13] IPC contribution to LV network efficiency and reliability
/Damien JEANNEAU / Vivien RINEAU/

Available: <https://www.esi-africa.com/wp-content/uploads/2015/12/Yannick-Henaff-Sicame.pdf>

[14] White Paper AP08324002E

http://www.eaton.com/ecm/groups/public/@pub/@eaton/@corp/documents/content/pct_1559746.pdf

[15] Own Energy Consumption of Smart Metering Infrastructure and Energy Monitoring Systems
Technical Report prepared for IEA 4E EDNA Task 1 - April 2016

Available: <http://www.iea-4e.org/document/386/own-energy-consumption-of-smart-metering-infrastructure-and-energy-monitoring-systems>

[16] Assessing the impact of photovoltaic self-consumption support policies on energy losses
/J. García-Villalobos / P. Eguía /E. Torres/A. Etxegarai/

Available: <http://www.icrepq.com/icrepq17/222-17-garcia.pdf>

[17] GEDISPER project Distributed generation impacts on network losses

Available:

http://www.energiaysociedad.es/wp-content/uploads/2016/10/20160919-GEDISPER_larga-EN.pdf

[18] The final report of GRID4EU

Available:

http://grid4eu.blob.core.windows.net/media-prod/29375/grid4eu-final-report_normal-res.pdf

[19] Cost benefit analysis of MV reactive power management and active power curtailment
CIRED Paper 0733 Glasgow 2017

/Leticia DE ALVARO GARCIA/ François BEAUNE/ Mathilde PITARD/
http://cired.net/publications/cired2017/pdfs/CIRED2017_0733_final.pdf

[20] First use of smart grid data in distribution network planning

/Guillaume ROUPIOZ/ Xavier ROBE/ Frédéric GORGETTE/

Available: http://www.cired.net/publications/cired2013/pdfs/CIRED2013_0609_final.pdf

[21] Management of electricity distribution network losses

Imperial College

Goran Strbac, Predrag Djapic, Enrique Ortega, Vladimir Stanojevic, Sana Kairudeen, Christos Markides, Andrew Heyes, Marko Aunedi, Dimitrios Papadaskalopoulos
Sohn Associates

Rodney Brook, David Hawkins, Brian Samuel, Tim Smith, Andy Sutton

<https://www.westernpower.co.uk/docs/Innovation-and-Low-Carbon/Losses-strategy/SOHN-Losses-Report.aspx>

[22] Management of electricity distribution network losses - Appendices

Imperial College

Goran Strbac, Predrag Djapic, Enrique Ortega, Vladimir Stanojevic, Sana Kairudeen, Andrew Heyes, Christos Markides, Marko Aunedi, Ekaterina Shamonina
Sohn Associates

Rodney Brook, David Hawkins, Brian Samuel, Tim Smith, Andy Sutton

<https://www.westernpower.co.uk/docs/Innovation-and-Low-Carbon/Losses-strategy/SOHN-Losses-Report-Appendices.aspx>

[23] Final results of LODIS project
František Müller
https://www.cez.cz/edee/content/file-other/distribucni-sluzby/konference-2016/05_janousek_macek_muller_en.pdf

[24] Variable renewable energy sources integration in electricity systems 2016 - How to get it right /World Energy Council, CESI/
<https://www.worldenergy.org/publications/2016/variable-renewable-energy-sources-integration-in-electricity-systems-2016-how-to-get-it-right/>

8.4. References on NTL part

nb : to be harmonized with other references ?

- [Agha 2016] A. Agha, A. Alfaoury, "Commercial losses in Jordanian electrical system (case study)", Proceedings of the 13th International Multi-Conference on Systems, Signals and Devices (SSD), 2016, pp. 189-193.
- [Angelos 2011] E. Angelos, O. R. Saavedra, O. A. Cortes, and A. N. de Souza, "Detection and identification of abnormalities in customer consumptions in power distribution systems," *IEEE Trans. Power Del.*, vol. 26, no. 4, pp. 2436–2442, Oct. 2011.
- [Antman 2009] P. Antmann, "Reducing Technical and Non-Technical Losses in the Power Sector", Background Paper for the World Bank Group Energy Sector Strategy, Energy Unit of the World Bank, July 2009.
- [Babu 2013] P. R. Babu, B. Sushma, "Operation and control of electrical distribution system with extra voltage to minimize the losses", Proceedings of the International Conference on Power, Energy and Control (ICPEC), 2013, pp. 165-169.
- [Bandim 2003] C. J. Bandim, J. E. R. Alves Jr., A. V. Pinto Jr., F. C. Souza, M. R. B. Loureiro, C. A. Magalhães, F. Galvez-Durand, "Identification of energy theft and tampered meters using a central observer meter: a mathematical approach," IEEE Conf. and Expo. PES Transmission and Distribution, Rio de Janeiro, Brazil, Sep. 2003, pp. 163–168.
- [Barioni 2015] C. Barioni, D. Antonelli, R. Wada, M. Menezes, J. Loureiro, H. Coêlho, "Estimation of energy consumption for DSO's revenue recovery due to consumers with proven irregular procedure", paper 0257, 23rd CIRED, Lyon, 2015.
- [Bastos 2009] P. R. F. M. Bastos, B. A. Souza, N. Ferreira, "Diagnosis of nontechnical energy losses using Bayesian networks", Proceedings of the 20th CIRED, Paper 0566, Prague, 2009.
- [Berrisford 2013] A. Berrisford, J. Dong, T. Xu, S. Maurice, A. de Castro, "Finding Topology Errors and Theft by Analyzing Smart Meter Data", Utility Analytics Week Conference Atlanta, Georgia, USA, Sep 2013.
- [Beutel 2015] A. A. Beutel, B. W. McLaren, R. Sander, S. J. van Zyl, J. Beukes, R. Asmal, H. J. Geldenhuys, E. Mpshe, "Public safety challenges in the context of the Universal Access Programme (UAP)", Paper 016, Joint CIGRE-IEC Symposium, Cape Town, Oct 2015.
- [Cavdar 2004] H. Cavdar, "A solution to remote detection of illegal Electricity usage via power line communications," *IEEE Trans. Power delivery*, vol. 19, No. 4, Oct 2004.
- [Chauhan 2013] A. Chauhan and S. R. Rajvanshi, "Non-technical losses in power system: a review", Proceedings of the International Conference on Power, Energy and Control (IPEC), 2013, pp. 558-561.
- [Chauhan 2015] A. Chauhan, "Non-technical losses in power system and monitoring of electricity theft over low-tension poles", Proceedings of the 2nd International Conference on Advances in Computing and Communication

- [Culwell 2001] Engineering (ICACCE), 2015, pp. 280-284.
J. J. Culwell, "Research study quantifies energy theft losses", Metering International Issue 1, 2001.
- [Depuru 2011] S. S. S. R. Depuru, L. Wang, and V. Devabhaktuni, "Electricity theft: Overview, issues, prevention and a smart meter based approach to control theft," *Energy Policy*, Vol. 39, No. 2, pp. 1007–1015, 2011.
- [Depuru 2013] S. Depuru, L. Wang, V. Devabhaktun and R. C. Green, "High performance computing for detection of electricity theft," *Int. J. Elect. Power Energy Syst.*, vol. 47, pp. 21–30, May 2013.
- [Doorduyn 2004] W. A. Doorduyn, H. du T. Mouton, R. Herman and H. J. Beukes, "Feasibility study of electricity theft detection using mobile remote check meters", Proceedings of the 7th African Conference in Africa, pp. 373-376, 2004.
- [EDSO 2016] European Distribution System Operators for Smart Grids, "Smart network management with smart meter data", June 2016.
- [Emara 2013] H. Emara Kassem, M. Badr, S. Ali Ahmed, "Reduction of energy losses in electrical distribution systems", Proceedings of the 22nd CIRED, Paper 0176, Stockholm, 2013.
- [ENW 2015] Electricity North West, Losses strategy, April 2015.
- [ERGEG 2008] ERGEG 1, "Treatment of Losses by Network Operators – ERGEG Position Paper for public consultation", Ref E08-ENM-04-03, 15 July 2008.
- [ERGEG 2009] ERGEG, "Treatment of Electricity Losses by Network Operators ERGEG Position Paper – Conclusions Paper", Ref E08-ENM-04-03c, Feb 2009.
- [Eskom 2016] Eskom Holdings SOC Limited, Power Alert, 14 July 2016.
- [Gemignani 2009] M. Gemignani, C. Tahan, C. Oliveira, F. Zamora, "Commercial losses estimations through consumers' behavior analysis", Proceedings of the 20th CIRED, Paper 1005, Prague, 2009.
- [Guerrero 2013] J. I. Guerrero, J. Biscarri, Í. Monedero, R. Millán, F. Biscarri, C. León, "Detection of Non-Technical Losses: The Project MIDAS", Chapter 8 in *Advances in Secure Computing, Internet Services, and Applications*, published by IGI Global, Dec 2013.
- [Guymard 2013] M. Guymard, A. Niang, "Électricité-Sénégal: 40 milliards de pertes", *Energy for Africa*, Vol 17, pp. 14-16, Dec 2013.
- [Harabagiu 2005] G. Harabagiu, "Reduction Solution for losses caused by electric energy theft", Proceedings of the 18th CIRED, Turin, 2005.
- [Hossein 2015] M. Hossein Pourarab, S. Alishahi, N. Aghli, "Electric power theft detection using time domain reflectometer", paper 1480, 23rd CIRED, Lyon, 2015.
- [Ilo 2003] A. Ilo, J. Koppensteiner, M. Resichböck, P. Parra, H. Socorro, L. Rodríguez, T. Romero, R. Cespedes, "On-line estimation and location of non-technical losses in a distribution system", Proceedings of the 17th CIRED, Paper 39, Barcelona, 2003.
- [Jokar 2016] P. Jokar, N. Arianpoo and V. C. M. Leung, "Electricity theft detection in AMI using customers' consumption patterns", *IEEE Transactions on Smart Grid*, Vol. 7, No. 1, 2016, pp. 216-226.
- [Leite 2016] J. B. Leite, J. R. S. Mantovani, "Detecting and locating non-technical losses in modern distribution networks", *IEEE Transactions on Smart Grid*, Vol. PP, Issue 99, 2016, pp. 1-1.
- [Lu 2013] C. Lu, S. Huang, Y. Lo, "Non-technical loss detection using state estimation and analysis of variance", Proceedings of the IEEE Power & Energy Society General Meeting, 2013.
- [Mashima 2012] D. Mashima and A. A. Cárdenas, "Evaluating electricity theft detectors in smart grid networks," in *Research in Attacks, Intrusions, and Defenses*. Berlin, Germany: Springer-Verlag, 2012, pp. 210–229.
- [McLaughlin 2013] S. McLaughlin, B. Holbert, A. Fawaz, R. Berthier, and S. Zonouz, "A multi-sensor energy theft detection framework for advanced metering infrastructures," *IEEE J. Sel. Areas Commun.*, vol. 31, no. 7, pp. 1319–1330, Jul. 2013.
- [Monedero 2011] I. Monedero, F. Biscarri, C. León, J. I. Guerrero, J. Biscarri, R. Millán,

- "Detection of frauds and other non-technical losses in a power utility using Pearson coefficient, Bayesian networks and decision trees", International Journal of Electrical Power & Energy Systems, Vol 34, pp. 90-98, Dec 2011.
- [Nagi 2009] J. Nagi, "An intelligent system for detection of non-technical losses in Tenaga Nasional Berhad (TNB) Malaysia low voltage distribution network", Masters These, Universiti Tenaga Nasional, 2009.
- [Navani 2012] J. P. Navani, N. K. Sharma, S. Sapra, "A case study of analysis of technical and non-technical losses in power system and its impact on power sector", International Journal of Advances in Engineering Science and Technology (IJAEST), Vol. 1, No. 2, pp. 137-146, 2012.
- [NEPCO 2014] National Electric Power Company NEPCO Annual Report, 2014, Amman, Jordan.
- [News 2002] K. Sullivan, "Power pirates leave Mexico City in the dark," Washington Post 20, APA, 2002.
- [News 2010-10] CBC News, "Electricity theft by B.C. grow-ops costs \$100M a year", <http://www.cbc.ca/news/canada/british-columbia/electricity-theft-by-b-c-grow-ops-costs-100m-a-year-1.969837>, 8 Oct 2010, Last accessed 29 Jul 2016.
- [News 2013-02] S. Battaglia, "Energy theft goes global", The Energy Collective Website, <http://www.theenergycollective.com/sbattaglia/185556/energy-theft-goes-global>, 13 Feb 2013, last accessed 25 Jul 2016.
- [News 2014-12] News report, "How much electricity is stolen in South Africa", <http://businesstech.co.za/news/general/75246/how-much-electricity-is-stolen-in-south-africa/>, 8 Dec 2014, last accessed 21 Jul 2016.
- [News 2015-01] News report, "Illegal electricity connections: power cuts and death", <http://mybroadband.co.za/news/energy/116424-illegal-electricity-connections-power-cuts-and-death.html>, 7 Jan 2015, last accessed 21 Jul 2016.
- [News 2015-02] News report, "Unprotected live wire leads to teen's death", New Age newspaper, <http://www.thenewage.co.za/unprotected-live-wire-leads-to-teens-death/>, 18 Feb 2016, last accessed 25 July 2016.
- [News 2015-03] News report, "Zandspruit protests get ugly", <http://www.thenewage.co.za/zandspruit-protest-gets-ugly/>, 16 Mar 2016, last accessed 25 July 2016.
- [News 2016-03] News report, "Robbing Eskom blind", <http://www.thenewage.co.za/robbing-eskom-blind/>, 22 Mar 2016, last accessed 25 July 2016.
- [News 2016-05] L. Charter, "Cable theft costs BCM R10/year", Daily Dispatch news article, <http://www.dispatchlive.co.za/cable-theft-costs-bcm-r10myear/>, 30 May 2016, last accessed 25 July 2016.
- [News 2016-07] S. Mathews, "Eskom counts on prepaid meters to fix nonpayment", Business Day news article, <http://www.bdlive.co.za/business/energy/2016/05/03/eskom-counts-on-prepaid-meters-to-fix-nonpayment>, 3 May 2016, last accessed 25 July 2016.
- [News 2016-08] ESI-Africa, "Uganda: Umeme tackles illegal electricity connections", <https://www.esi-africa.com/news/umeme-tackles-illegal-electricity-connections/>, 25 Aug 2016, last accessed 2 Sep 2016.
- [OFGEM 2015] Office of Gas and Electricity Markets, "Energy Efficiency Directive: An assessment of the energy efficiency potential of Great Britain's gas and electricity infrastructure", June 2015.
- [Parra 2006] J. L. Parra, E. A. S. Calderon, "Use of shunts detecting equipment for the identification of illegal power outlets", Proceedings of the IEEE/PES Transmission & Distribution Conference and Exposition, Latin America, Caracas, Venezuela, Aug 2006, pp. 1-4.
- [Pasdar 2007] A. Pasdar, S. A. Mirzakuchaki, "A solution to remote detecting of illegal electricity usage based on smartmetering", Proceedings of the International Workshop on Soft Computing Applications, Oradea, Romania, Aug 2007, pp. 163-167.

- [Rengaraju 2014] P. Rengaraju, S. R. Pandian, C. Lung, "Communication networks and non-technical energy loss control system for smart grid networks", Proceedings of the IEEE Innovative Smart Grid Technologies – Asia (ISGT ASIA), 2014, pp. 418-423.
- [Ribeiro 2012] S. S. Ribeiro, T. Cazes, R. F. Mano, D. Maia, "Investment optimization methodology applied to investments on non-technical losses reduction actions", Proceedings of the IEEE Symposium on Computers and Communications (ISCC), 2012, pp. 354-360.
- [Rossoni 2015] A. Rossoni, R. Trevizan, A. Bretas, D. Gazzana, A. Bettioli, A. Carniato, L. Passos, R. Martin, "Hybrid formulation for technical and non-technical losses estimation and identification in distribution networks: application in a Brazilian power system", Proceedings of the 23rd CIRED, Paper 1365, Lyon, 2015.
- [Santos 2015] S. Santos, C. Martínez, T. Arzuaga, L. Marron, "Future applications based on the data provided by next generation of smart meters", Paper 0718, 23rd CIRED, Lyon, 2015.
- [Smith 2004] T. B. Smith, "Electricity theft: a comparative analysis", Energy Policy, Vol. 32, No. 18, pp. 2067–2076, 2004.
- [SPEN 2014] SP Energy Networks 2015–2023 Business Plan, updated March 2014, Annex - Losses Strategy, v1.1, May 2014.
- [SPEN 2015] SP Energy Networks Losses Strategy, Sep 2015.
- [SSEPD 2015] Scottish & Southern Energy Power Distribution, SSEPD RIIO-ED1 Losses Strategy, April 2015.
- [Suriyamongkol 2002] D. Suriyamongkol, "*Non-Technical Losses in Electrical Power Systems*", Master's Dissertation, Ohio University, United States, 2002.
- [Transparency 1999] Transparency International, "Corruption in Public Sector Departments", Dacca, TI Bangladesh Documents, 1999.
- [Trupinic 2005] K. Trupinic, M. Stojkov, D. Poletto, "Reduction of non-technical losses based on time domain reflectometer (TDR) principles and function", Proceedings of the 18th CIRED, Turin, 2005.
- [UKRPA 2015] United Kingdom Revenue Protection Association, "Sentencing Council Publishes Guideline for Electricity Theft Offences", Press release, 7 Oct 2015.
- [Yorukoglu 2016] S. Yorukoglu, F. Nasibov, M. Mungan, M. Bagriyanik, "The effect of the types of network topologies on non-technical losses in secondary electric distribution systems", Proceedings of the 52nd IEEE IAS Industrial and Commercial Power Systems Technical Conference (I&CPS), 2016, pp. 1-14.
- [WPD 2015] Western Power Distribution, Losses Strategy, Jan 2015.