

## MVDC LINK IN A 33 kV DISTRIBUTION NETWORK

Chao LONG  
Cardiff University – UK  
chao.long.10@gmail.com

Jianzhong WU  
Cardiff University – UK  
wuj5@cardiff.ac.uk

Kevin SMITH  
SP Energy Networks  
kevin.smith@spenergynetworks.co.uk

Andrew MOON  
EA Technology – UK  
andrew.moon@EAtechnology.com

Russell BRYANS  
TNEI Services, UK  
russ.bryans@tnei.co.uk

James YU  
SP Energy Networks  
james.yu@spenergynetworks.co.uk,

### ABSTRACT

*The performance of a 33 kV distribution network with a proposed medium voltage DC (MVDC) link between the island of Anglesey and the mainland in North Wales was assessed. The MVDC link, which will be constructed as part of the Ofgem Electricity Network Innovation Competition project ANGLE-DC, was simulated under a wide range of demand and generation, with control strategies based on real-time data from the three 132/33 kV grid transformers (GTs) that supply the island network or the wider SCADA system. The active power set-points of the MVDC link for the GT data based control were determined by a sensitivity analysis of the network losses. For the wider SCADA system based control, optimal set-points were obtained using an optimal power flow (OPF) method. The network losses and hosting capacity for distribution generation (DG) were assessed considering both normal network and N-1 conditions. This work found that the use of the MVDC link increased the DG hosting capacity of the network, but network losses might be increased or reduced depending on the load and generation conditions, and control strategies.*

### INTRODUCTION

UK electricity distribution networks need to adapt for the future energy scenarios which aims to reduce carbon emissions, in the power sector, to near zero by 2050 [1]. Distributed Generation (DG) capacity is predicted to nearly double to approximately 21.8 GW in GB by 2035 [2]. The UK Carbon Plan promotes the electrification of heating and transport and the use of renewable energy sources, which will mainly be connected to distribution networks. Consequently, Distribution Network Operators (DNOs) face a challenge to accommodate significant demand and DG growth. Thus, potentially extensive and expensive reinforcement of the distribution networks may be required.

Conventional circuit reinforcement typically involves significant costs and additional land requirements. Obtaining way-leave agreements or easements could directly affect the lead time of distribution network expansion schemes. This may also result in lengthy lead times for renewable connections. Solutions for future distribution networks need to make the most efficient use of existing assets, thus potentially deferring or avoiding

the need for network reinforcement.

Most GB distribution systems are traditionally operated radially; neighbouring networks are not operated with interconnection, as coupling distribution systems may result in thermal ratings, fault level limits and permissible voltage levels being exceeded. However, a direct and controlled power exchange between distribution systems allows the transfer of the excessive power generated by DGs to other load centres. A reliable and controlled interconnection between distribution systems could potentially reduce network losses, enhance the reliability of the system, and reduce customer interruptions by increasing the power supply paths.

Renewable resources are intermittent and their export does not necessarily coincide with local demand. This along with the inherent uncertainty of generation and demand requires future distribution networks to be flexible and controllable. Technical challenges include a combination of thermal overloading, voltage excursions and breaching fault level limits. These challenges result in delays and restrictions on the connection of low carbon generation.

Medium Voltage DC (MVDC) links have been identified as a potential enabler to mitigate these issues. The use of MVDC technology has the potential to provide rapid control of voltage and power flows and so increase the capacity of networks to transport power. MVDC has not, so far, been used in distribution networks in the UK and this work offers an early opportunity to investigate its use and benefits.

### ANGLE-DC PROJECT

Ofgem awarded funding for the ANGLE-DC project in November 2015, as an Electricity Network Innovation Competition project [3]. ANGLE-DC (initiated by SP Energy Networks) aims to demonstrate the application of MVDC technology by converting an existing 33 kV AC double-circuit circuit to a symmetrical monopole DC circuit; each AC circuit becomes one pole, operating at  $\pm 27$  kV DC. The double circuit is between Llanfair PG substation, on Anglesey Island, and Bangor substation on the mainland in North Wales. An AC/DC converter station will be installed at each end of the circuit. The existing AC circuit consists of underground cables and an overhead line, and the total length is approximately 3km.

### Anglesey Network Issues

The 33 kV system on Anglesey is currently approaching both thermal and voltage limits. The demand in Anglesey is anticipated to increase significantly over the next 10 years due to various regeneration and development projects by the Welsh Government and the Horizon Nuclear Power station development. The level of requests for generation connection in the area is extremely high and it is anticipated to double over the next few years. Fig. 1 shows the 33kV circuits in Anglesey and the nearby mainland, and each green dot is a 33/11 kV substation.

A 33kV circuit, connecting Llanfair PG to other parts of the North Wales distribution network (Bangor), has been identified as a location where uncontrolled power flows are forecast to exceed thermal limits. Additionally the circuit is located in an area where voltage management is becoming increasingly difficult. To overcome these problems, there is a need to control power flows on the 33 kV network between the island and North Wales, and increase transfer capacity.

### ANGLE-DC project

This project will be the first in the UK to trial Voltage Source Converters (VSCs) for operation in an MVDC circuit [4]. DC technology has been used to some degree at MV for industrial and back-to-back (B2B) applications, but it has not been widely used and exploited. This project is developing a fit for purpose specification for an appropriate, cost effective and easily repeatable solution for future applications.

The re-use of existing AC assets represents a significant innovative step in the use of MVDC technology. Avoidance of the need for new circuits will accelerate access to the network for low carbon renewable generators because construction of converter stations is expected to be quicker than construction of a new circuit.

A B2B solution requires a specific location, typically a Normally Open Point (NOP), whereas this project will demonstrate more general application of MVDC. It will demonstrate the flexibility of operating in two electrical and physical environments and prove the communication needs between the stations. The benefit from the deployment of MVDC converters at both ends of a link, rather than a B2B application, is that it can enable power and voltage control over a wider area and increase capacity of existing circuits.

### Benefits

The benefits of using MVDC technology are summarised:

- The use of AC circuits at DC increases the thermal capability allowing for more power to be transported without any new circuits;

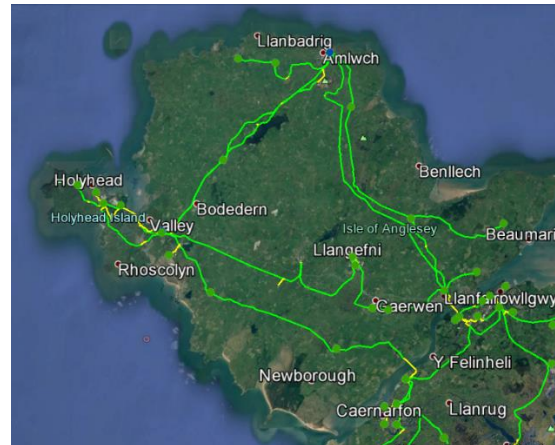

**Figure 1.** 33 kV circuits in the Anglesey region in North Wales, UK

- MVDC technology allows for full controllability of power flows and improved voltage regulation;
- With an appropriate control strategy, network losses could be reduced. Over the lifetime of the assets, this reduction in network losses is significant;
- The degree of controllability offered by DC would enable network NOPs to be closed in circumstances that would otherwise lead to unacceptable thermal overloads or fault levels. As a consequence reliability of the network could be improved;
- The establishment of a DC link could in some situations avoid or defer the need for wider distribution network reinforcement; An AC/DC conversion scheme could be delivered faster than a conventional reinforcement where way-leaves are likely to be an issue.

## **ANGLESEY NETWORK MODELLING**

### Network Topology

The Anglesey 132 and 33 kV network is shown in Fig. 2, with part of the 33 kV circuit on mainland. The meshed Anglesey 33 kV network is supplied by three 132/33kV transformers. The MVDC link will be the only medium voltage connection between Anglesey and the mainland. Three wind farms with a total peak capacity of 34.7 MW and two solar farms with a total peak of 28.5 MW are already installed on Anglesey and more distributed generators with approximately 68 MW of peak capacity will be installed in the next few years.

### Demand

In the studies, active power demand on Anglesey was varied in five levels between 25 MW and 82 MW, corresponding to: summer minimum (25 MW), summer maximum (38 MW), existing winter maximum (75 MW), forecasted winter maximum in 2019 (78 MW), forecasted winter maximum in 2023 (82 MW).

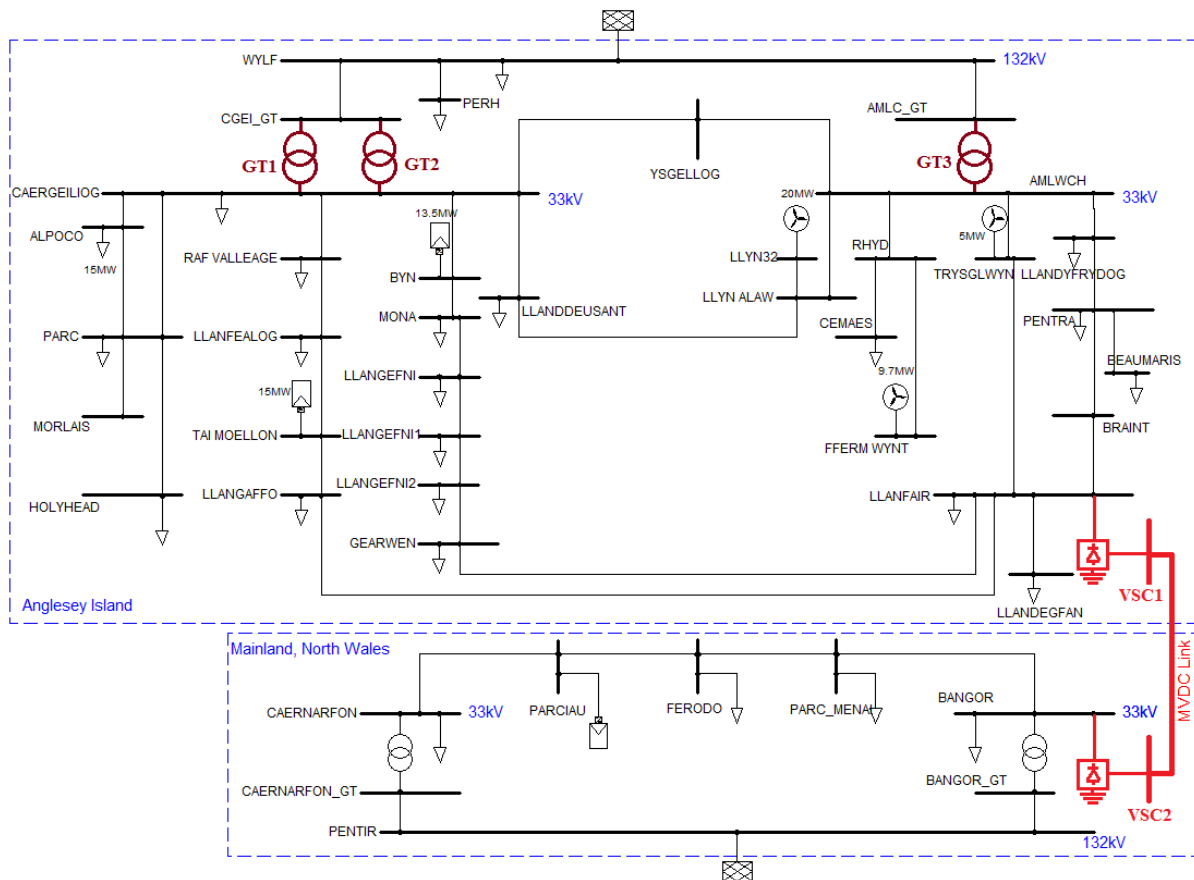

Figure 2. 33 kV network circuit on Anglesey, UK

### Distributed Generation

In the studies, generation on Anglesey was varied in 20% increments between 0 MW and maximum contracted generation capacity of 125 MW.

The net load and hence the power flows through the 3 grid transformers for the 25 combinations of load and generation is shown in Table 1.

Table 1 Net load on the Anglesey network

		Demand (MW)				
		S <sub>MIN</sub>	S <sub>MAX</sub>	W <sub>MAX</sub>	W <sub>max2019</sub>	W <sub>max2023</sub>
Generation (MW)	0	25	38	75	78	82
	31	-6	7	44	47	51
	63	-38	-25	12	15	19
	94	-69	-56	-19	-16	-12
	125	-100	-87	-50	-47	-43

### POSSIBLE MVDC CONTROL STRATEGIES

The MVDC link is rated 30.5 MVA, with a power factor between 0.9 exporting and importing Vars at either terminals. The AC/DC converters of the MVDC link will have the ability to control the active power direction and

magnitude as well as the reactive power at both terminals. According to the level of communications, two control strategies were investigated:

- Grid Transformer (GT) data based control.** It is assumed that communication links between Anglesey GTs (i.e. the three 132/33 kV transformers) and the controller of the MVDC link are available. The total active power flowing through the GTs is used to provide the set-point of the active power control of the DC link. At each MVDC terminal, the converter is operated in voltage control mode. In other words, the two 33 kV busbars of Llanfair PG and Bangor substations are voltage buses, where the operator selects a target voltage, and the MVar output is continuously adjusted accordingly, absorbing or generating reactive power to achieve the desired voltage.
- Wider SCADA system based control.** The studies assumed that communication links between the SCADA system of the 33kV network and the controller of the MVDC link are available. This will provide demand data at each 33/11 kV substation and generation data at the 33 kV Anglesey network allowing the controller to carry out power flow optimisation. The set-points of the active power of the DC link, and reactive power of both terminals are the decision variable for the optimisation. Thus,

optimal operation of the MVDC link is found. When there is a loss of communication with the SCADA system, the controller of the MVDC link falls back to the GT data based control

### GT Data Based Control

#### Sensitivity Analysis of Network Losses

A sensitivity analysis was carried out quantifying power losses for different scenarios of demand, generation and MVDC active power set-points. The active power set-point was varied in 5 MW increments, from -25 to 25 MW, where negative values indicate export of active power from Anglesey to North Wales, and positive values indicate import power from North Wales to Anglesey. The voltage set-point at both converter stations was set as 1 pu

Fig. 3 shows the power losses of Anglesey network without DG and with different active power set-points of the MVDC link. For each load, the set-point which resulted in the minimum network losses is shown in the first row of Table 2. Four additional sets of values were obtained for the remaining DG scenarios.

#### MVDC Link Active Power Set-point

Fig. 4 shows the operation curve for the active power set-points using the GT data based control. This curve was obtained by a linear approximation of the results shown in Table 2. The least squares method was used for the linear approximation to find the most appropriate operation curve. It shows that the active power set-points were between -15 and 25 MW. For maximum generation and minimum load, the MVDC link exports ~15 MW to the mainland; for minimum generation and maximum load, the MVDC link imports ~25 MW to Anglesey. The more frequent behaviour of the MVDC link is to import power from North Wales to Anglesey.

#### Wider SCADA System Based Control

Optimal set-points of the active power of the MVDC link, and reactive power of both terminals were found [5]. The objective was to minimise the total losses of the Anglesey 132 and 33 kV networks. The constraints included the voltage and thermal limits, maximum and minimum of the active and reactive power of the MVDC link.

### CONTROL STRATEGY COMPARISON

Performances of the network with the MVDC link operating with GT data only and a wider SCADA system based control strategies were compared with the Business As Usual (BAU) case (i.e. an AC connection between Llanfair PG and Bangor).

#### Network Losses

Network losses were examined under a wide range of demand and generation scenarios, and with different control strategies. It was found that under scenarios of low and medium levels of DG, the GT data based control

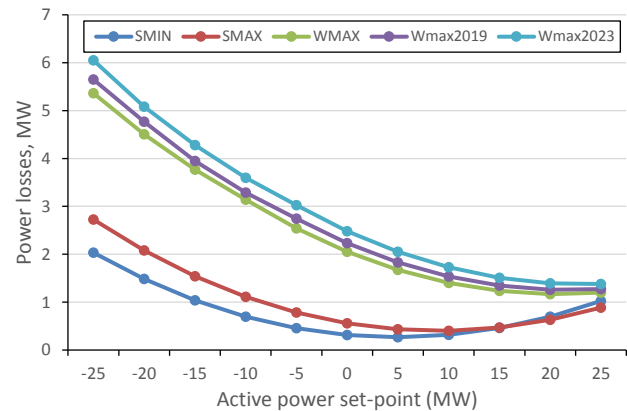

Figure 3. Anglesey network power losses at 0 MW DG

Table 2 Active power set-point of MVDC link resulted from the sensitivity analysis of network losses

		Demand (MW)				
		SMIN	SMAX	WMAX	Wmax2019	Wmax2023
Generation (MW)	0	5	10	20	25	25
	31	0	5	20	20	25
	63	-5	0	15	15	15
	94	-10	-5	10	10	10
	125	-15	-10	5	5	5

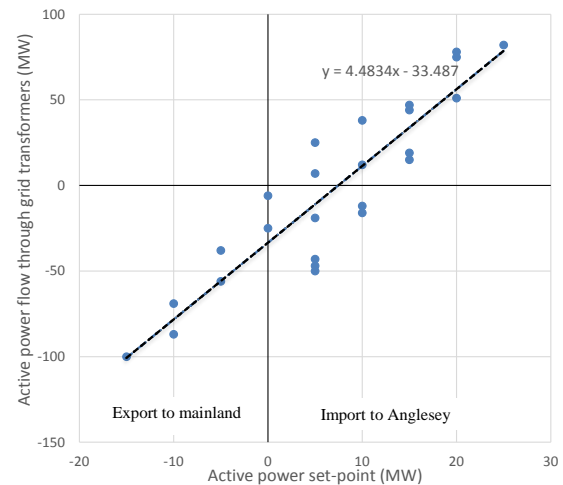
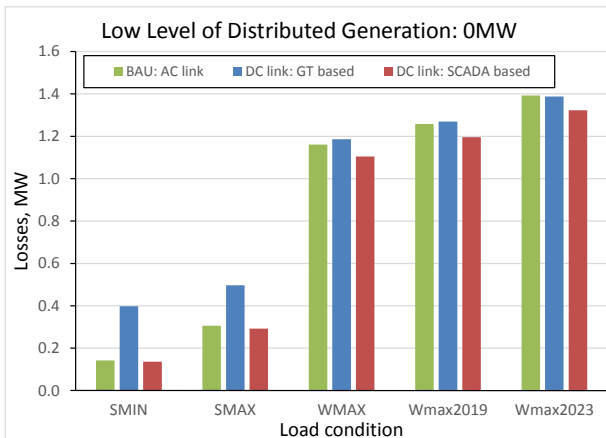

Figure 4. Operation curve for active power set-points using the GT data based control

resulted in increased network losses compared to the case with AC link, as seen in Fig. 5(a) and 5(b). This is due to the reactive power injections by the two converter stations. For higher DG, the GT data based control had reduced losses compared to the case with AC link, as shown in Fig. 5(c). The wider SCADA based control always resulted in the minimum network losses among the three cases.

#### Network's DG Hosting Capacity

The use of the MVDC link increased the network hosting capacity, regardless the control strategies used. Despite the



(a)

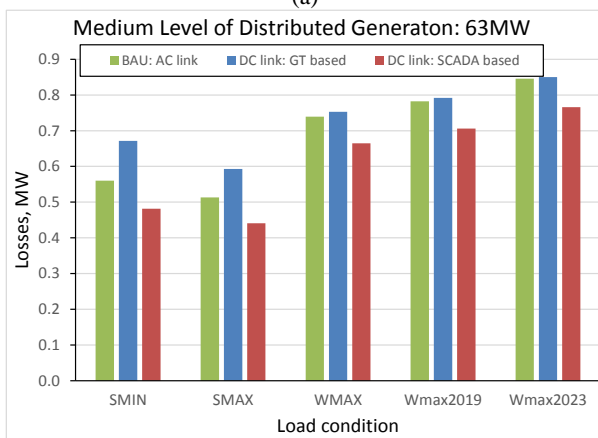

(b)

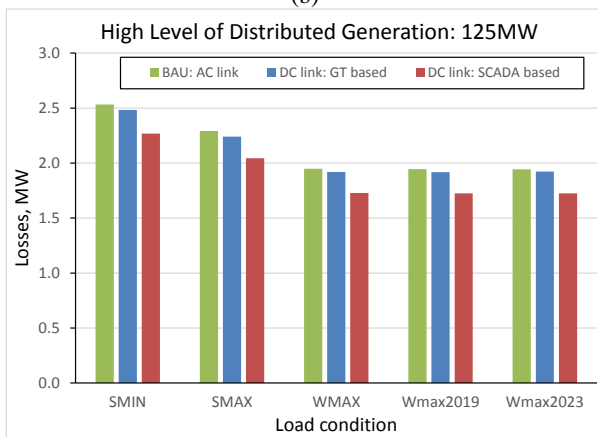

(c)

**Figure 5.** Anglesey network losses in different load and DG conditions

GT data based control resulting in more losses than the wider SCADA system based control, they provide similar headroom capacity for the Anglesey network to host DG.

### NETWORK N-1 CONDITION

Performance of the network was also assessed under the N-1 conditions. It is found that import or export flows of greater than  $\pm 20$  MW started to risk thermal constraints

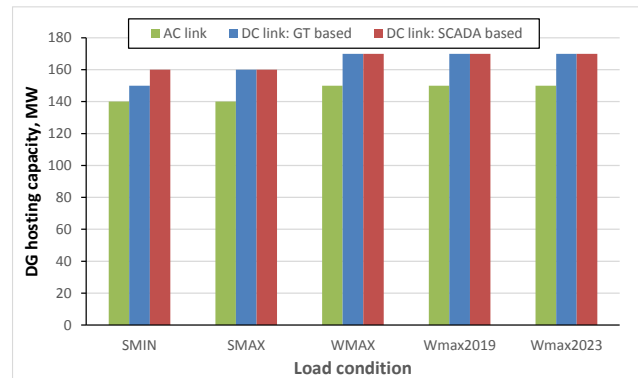
**Figure 6.** Anglesey network's DG hosting capacity

under the N-1 condition. This affected the operation set-points for minimum generation and maximum load. This has minor influence on the network loss analysis.

### CONCLUSIONS

The network performance of an MVDC link in a 33 kV distribution network was investigated. This work found that the use of an MVDC link increased the MV network's DG hosting capacity, but the network losses depend on the load and generation conditions and control strategy. A GT data based control might result in increased network losses, due to its injection of reactive power for voltage support, whilst a wider SCADA system based control result in minimum network losses. However, the controller has to fall back to the GT data based control when there is loss of communication between the converter controller and the wider SCADA system.

### REFERENCES

- [1] HM Government. The Carbon Plan: Delivering our low carbon future. 2011.
- [2] Energy UK, Pathways for the GB Electricity Sector to 2030, Feb. 2016
- [3] Ofgem. (accessed 2016, August 4). Electricity NIC submission: SP Energy Networks – ANGLE-DC [Online] Available: <https://www.ofgem.gov.uk/publications-and-updates/electricity-nic-submission-sp-energy-networks-angle-dc>
- [4] J. Yu et al. "Initial designs for ANGLE-DC project: Challenges converting existing AC cable and overhead line to DC operation", CIRED 2017, Glasgow, submitted.
- [5] C. Long, J. Wu, L. Thomas, N. Jenkins, 2016, "Optimal operation of soft open points in medium voltage electrical distribution networks with Distributed Generation", Applied Energy. vol. 184, 427-437.