

OPERATION AND CONTROL OF DG BASED POWER ISLAND IN SMART GRID ENVIRONMENT

S.P.CHOWDHURY
Jadavpur University–India
spchowdhury63@yahoo.com

S.CHOWDHURY
Women's Polytechnic–India
sunetra69@yahoo.com

C.F.TEN
University of Manchester–UK
chui.ten@postgrad.manchester.ac.uk

P.A.CROSSLEY
University of Manchester - UK
p.crossley@manchester.ac.uk

ABSTRACT

This paper presents a simulation study of operation and control of distributed generators (DGs) in power islands in Smart Grid environment. It examines the technical feasibility of DG islanding operation to exploit their services for improving electrical safety, security and quality of energy supply. The grid-connected DGs are initially operated at PQ mode and then switched to V-f mode to have full controllability of bus frequency and voltage when operated as independent power island. Suitable controllers are designed separately for individual control of voltage and frequency at the DG bus. The simulation results are validated through several case studies using DIGSILENT software for both intentional and unintentional loss of grid (LOG) situations. It has been observed that when several islanded DGs are interconnected to form a power island, they can share the active and reactive power demands of the island leading to quick restoration of the system voltage and frequency within permissible bandwidth.

INTRODUCTION

With growing power demand and increasing concern about the use of fossil fuels in conventional power plants, the new paradigm of distributed generation is gaining greater commercial and technical importance across the globe. Distributed generation involves the interconnection of small-scale, on-site distributed generators (DGs) with the main power utility at distribution voltage level [1]. DGs constitute non-conventional and renewable energy sources like solar photovoltaic, wind turbines, fuel cells, mini-hydro, micro-turbines etc. These generation technologies are being preferred for their high energy efficiency, low environmental impact and their applicability as uninterruptible power supplies. Electric energy market reforms and developments in electronics and communication technology are currently enabling the control of geographically distributed DGs through advanced SCADA [2]. R.H.Lasseter et. al. [3] have discussed how interconnected DGs can be efficiently operated as microgrids both in grid-connected mode and islanded mode.

A high degree of DG penetration (more than 20%) as well as their placement and capacity with respect to the utility grid, have considerable impact on operation, control, protection and reliability of the existing power system [3][4][5]. These issues must be critically assessed and resolved before allowing the market participation of DGs.

This is necessary for fully utilising DG potential for generation augmentation, enhancing power quality and reliability and for providing auxiliary services such as active reserve, load-following, interruptible loads, reactive reserve, restoration etc. [6].

Literature survey indicates that extensive work has been done to elucidate the impacts of DG penetration on utility system and to provide possible solutions. Most critically affected area is protection coordination of the utility distribution system. Singly-fed and passive utility distribution networks are converted to multi-fed networks after DG insertion. This changes the flow of fault currents from unidirectional to bi-directional which affects the coordination of the existing protective devices. Other impacts include i) false tripping of feeders and protective devices, ii) blinding of protection, iii) change of fault levels with connection and disconnection of DGs, iv) unwanted islanding, v) prevention of automatic reclosing and vi) out of synchronism reclosing [7][8].

Keeping these in view, technical recommendations like G83/1, G59/1, IEEE 1547, CEI 11-20 prescribe that DGs should be automatically disconnected from the MV and LV utility networks, in case of tripping of the circuit breaker (CB) supplying the feeder connected to the DG. This is known as the anti-islanding feature and is incorporated as a mandatory feature in the inverter interfaces for commercially available DGs. Anti-islanding systems are mainly used to ensure personnel safety at the grid end and to prevent any out of synchronism reclosure. As the DGs are not under direct utility control, use of anti-islanding protection is justified by the operational requirements of the utilities [9]. Extensive research is being carried out to develop low-cost and efficient digital anti-islanding schemes suitable for seamless operation of the inter-tie CBs for re-connection of the islanded zones without affecting original protection co-ordination of the utility grid [9-11][13-16].

Anti-islanding feature drastically reduces the benefits of DG deployment which could otherwise be exploited if DGs were allowed to operate as power islands as and when required. Intentional power island operation allows the DGs to operate as independent islanded network suitable for maintaining uninterruptible power supply to critical loads. At present, in spite of increasing DG penetration, power engineers, network operators, regulators and other stakeholders are hesitant to such initiatives. Different surveys indicate that the present scenario does not economically justify this mode of DG operation. However, technical studies [12][17] clearly indicate the need to review parts of

the Electricity Safety, Quality and Continuity Regulations (ESQCR) for successful islanding operations.

This paper investigates the technical feasibility of successful islanding operations with independent control of the power island. The simulation results are validated by several case studies.

CONTEXT OF THE WORK

Different surveys indicate that the present UK scenario does not economically justify islanding operation of active distribution networks with DGs. However, several studies are undertaken by Department of Trade and Industry (DTI), Technical Steering Group (TSG), Distributed Generation Co-ordinating Group (DGCG) and others for investigating the technical feasibility of islanded operation of DGs. Consultation has been done with selected Distribution Network Operators (DNOs), Gas and Electricity Market regulatory body of UK (Ofgem) and others to obtain their views on islanding. Literature review [12][17] confirms that islanding can be implemented from a technical standpoint. Technical reports clearly indicate the need to review and later on modify parts of the Electricity Safety, Quality and Continuity Regulations (ESQCR) to support power island operations [12][17]. Islanding studies reported in [12] and [17] indicate the DG and the induction motor loads within the system remains stable following the islanding event. But voltage and frequency variations exceed the acceptable limits laid down in the ESQCR, G59 and the BS EN 50160. The use of frequency sensitive load controllers within the island for adding and shedding loads, as needed, can damp the voltage and frequency excursions within acceptable limits. Currently, the limits for frequency and voltage excursions laid down in ESQCR are too stringent to allow seamless islanding to occur. However, it is probable that G59/1, G75, and Engineering Technical Report ETR 113/1 will be updated in future to accommodate DG islanding to harness the full benefits of DG deployment.

SYSTEM CONFIGURATION

For simulation of power island scenario, the authors consider System-1 and System-2 as shown in Fig.-1 and Fig.-2 respectively.

In System-1, two separate DG systems, GT#1 and GT#2 each comprising a 28.1 MVA, 11 kV gas turbine (GT) are separately connected to the grid at 11kV through 33/11kV transformers. ST#1 and GT#2 are again connected through an intertie at 11kV.

In System-2, three separate DG systems, GT#1, GT#2 and GT#3 are considered. Each consists of a 28.1 MVA, 11 kV GTs as in System-1. All the GTs are separately connected to the grid at 11kV through 33/11kV transformers. Moreover, GT#1, GT#2 and GT#3 are connected to one another through interties forming a delta.

For both systems, when the GTs are grid-connected at 11kV bus, they are operated in the PQ mode. The voltage

and frequency at the 11kV bus are regulated by the grid. When islanding takes place, the GTs are switched from PQ mode to V-f mode. Now the 11kV bus voltage and frequency are regulated by the GTs.

The grid is normally assumed to be of very high pool with respect to the DGs. In this simulation study the maximum and minimum short circuit levels of the grid are taken to be 5000 MVA and 4000 MVA respectively and the maximum level is used for study. Grid load at 33kV bus is taken to be 100kW while each GT is loaded to a maximum of 23 MW on islanding.

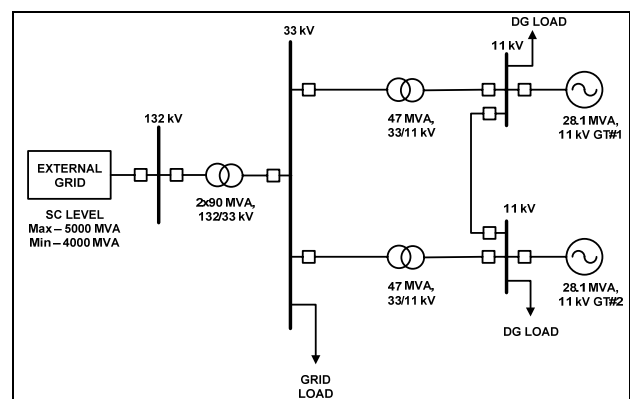

Figure-1 System Configuration with two DGs

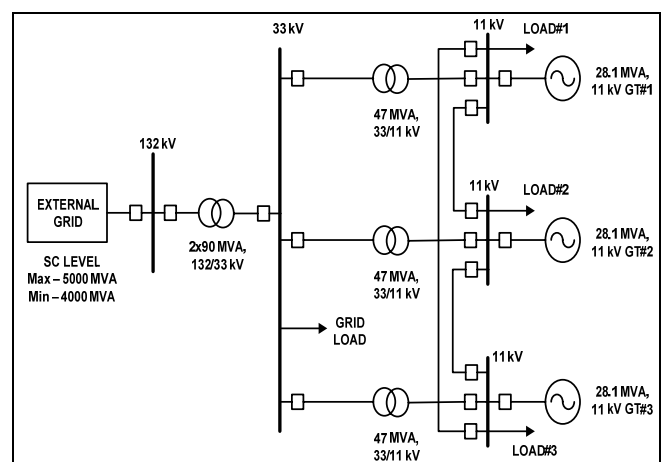

Figure-2 System Configuration with three DGs

CASE STUDIES

Case Study - 1(a)

In this case, GT#1 and GT#2 are initially connected to grid and operating in PQ mode. Each is maintained at a fixed generation of 20MW while the rest of GT load is shared by the grid. The intertie is open. Simple islanding takes place at t=25 s by opening the 33/11 kV transformer feeders. On islanding, the GTs are switched on from PQ to V-f mode. The intertie line between GT#1 and GT#2 is kept open. Simulation plot of bus voltages and frequency at one of the 11kV buses (where GT#1 is connected) as shown in Figure

3 indicate that voltage takes about 8 seconds and system frequency takes about 7 seconds to settle after islanding. The controllers are capable of arresting the voltage and frequency excursions within permissible limits. The voltage and frequency responses for the GT#2 11kV is exactly the same as islanding takes place at the same time. Hence only GT#1 bus results are plotted.

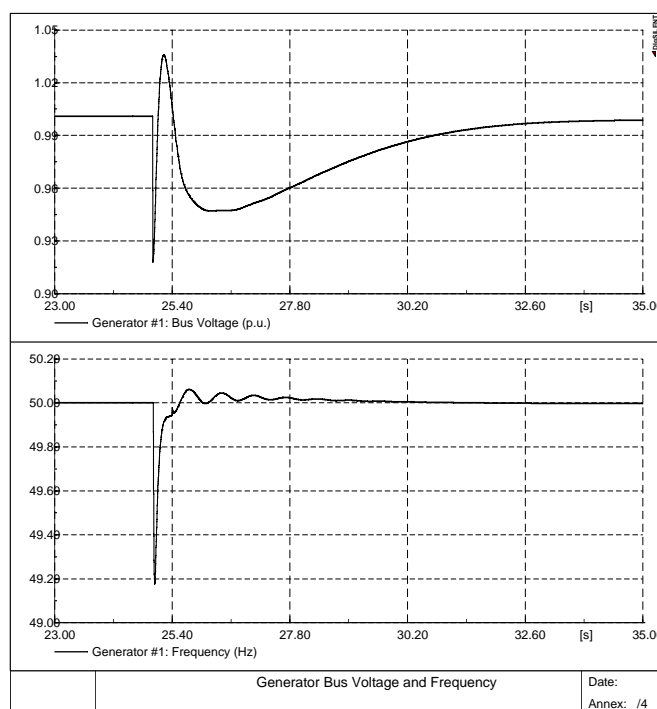

Figure-3 Bus Voltage and Frequency for Case Study - 1(a)

Case Study - 1(b)

This case is similar to Case-1(a) except that the inertia between GT#1 and GT#2 is closed on islanding at t=25s. In this case, only GT#1 is switched from PQ mode to V-f mode while GT#2 is maintained at the fixed generation of 20 MW. On islanding, the extra load of GT#2 is shared by GT#1 and the bus voltage and frequency at both the 11kV buses are regulated by GT#1 controller. Here, GT#1 is designated as the master DG and GT#2 as the slave DG. Bus voltage and frequency plots for GT#1 and GT#2 11 kV buses are shown in Figure 4. Plots indicate that the bus voltage takes about 11 seconds while system frequency takes about 10 seconds to settle after islanding. The bus voltage of the GT#2 (slave DG) is slightly less than that of the master DG bus due to the drop across the inertia. The master controller is quite capable of arresting the voltage and frequency excursions of the island within permissible limits. It has been seen from simulation that both the GTs are capable of becoming the master controller, with the other being the slave. Similar responses are obtained with GT#2 as the master and GT#1 as the slave.

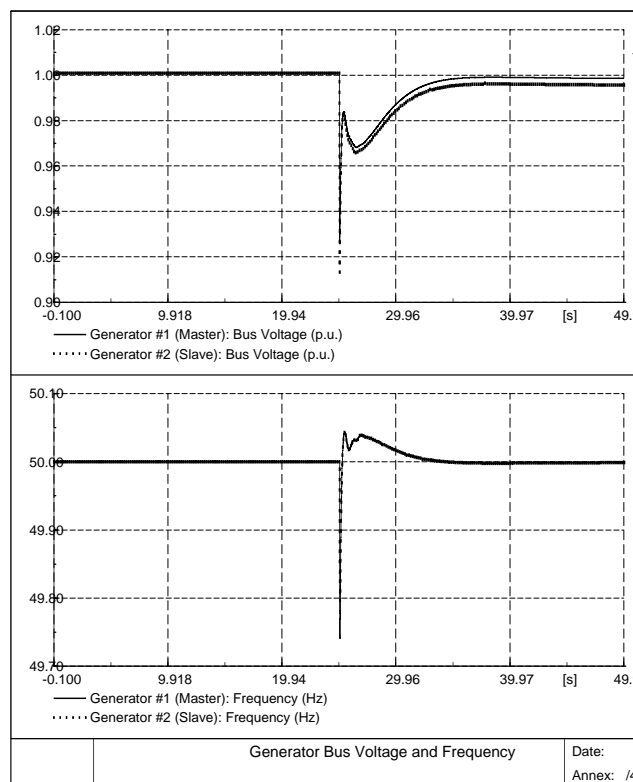

Figure-4 Bus Voltage and Frequency for Case Study - 1(b)

Case Study- 2(a)

In this case, simple islanding takes place for all the three GTs at t=25 seconds. GT#1 is designated as the master controller while GT#2 is the slave maintained at fixed generation of 20MW. GT#3 is self-controlled. The inertias between GT#1 and GT#2 is closed on islanding while the others are kept open. On islanding, GT#1 switches from PQ to V-f mode for maintaining the 11 kV bus voltages and frequency for GT#1 and GT#2. GT#3 also switches from PQ to V-f mode to regulate its own 11kV bus voltage and frequency. Thus two independent power islands are formed – one consisting of GT#1 and GT#2 and the other consisting of GT#3 alone. Simulation plots are shown in Figure 5. The frequency and bus voltage characteristics for GT#1 and GT#2 are same as case-1(b) and that of the GT#3 are same as case-1(a). It is clearly seen that when the DGs are interconnected then their voltage and frequency dip transient responses are better than that of the non-interconnected DG. But single DG takes lesser time than interconnected ones. Nevertheless, the voltage and frequency excursions are within permissible limits for both the islands.

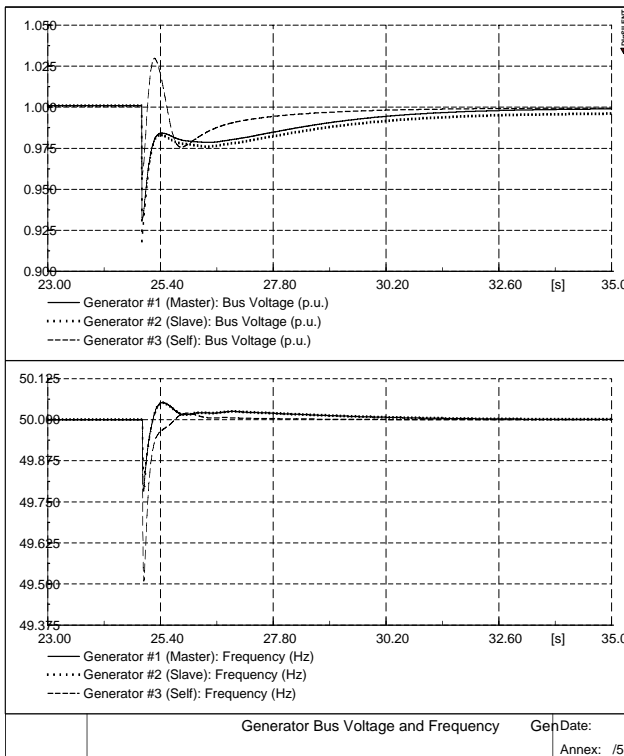

Figure-5 Bus Voltage and Frequency for Case Study - 2(a)

Case Study- 2(b)

This case is similar to case-2(a). However, here GT#1 is the master controller and GT#2 and GT#3 are slaves maintained at fixed generation. Simple islanding takes place for all the GTs at t=20 seconds. On islanding all the interties are closed and only GT#1 switches from PQ to V-f mode.

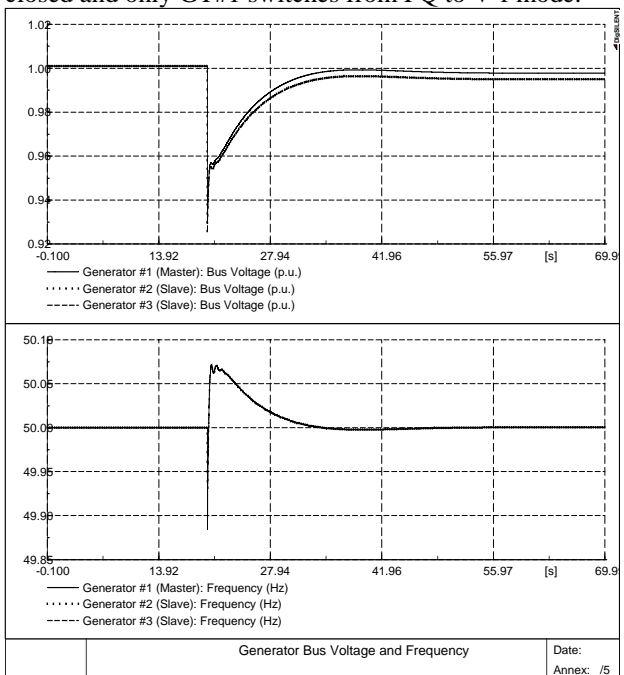

Figure-6 Bus Voltage and Frequency for Case Study - 2(b)

The voltage and frequency responses at 11 kV GT buses are shown in Figure 6. These are similar to those in Case-1(b). The voltages at the buses of the slave DGs (GT#2 and GT#3) are somewhat less than that of the master DG (GT#1) bus due to intertie voltage drops. The voltage and frequency excursions are within permissible limits for the island. It has been seen that any of the GTs can be used as the master with the other being slaves. The responses tested with GT#2 and GT#3 as the master are found to be similar to Case-2(b).

It has also been observed that the performance of interconnected DGs is better in terms of security and quality of supply during islanding situations.

CONCLUSION

The DG paradigm has created widespread interest in power system planning and research in recent years amongst energy planners, policy makers, regulators, generators and researchers. Resolving of technical and economic issues related to interconnection of non-conventional and renewable DERs has been a major thrust of work in this area. This paper presents successful islanding operation of DGs. The DGs are not allowed to control bus voltage and frequency when operated in parallel with the grid, as per the safety and security regulations G59/1 and IEEE1547. Hence the DGs are operated in PQ mode in the active distribution network when remain connected to the grid. These are switched from PQ mode to V-f control mode during islanding for maintaining the bus voltage and frequency within permissible bandwidth. Two separate controllers are used for independent control of DG bus voltage and system frequency. The simulation results clearly indicate the technical feasibility of operation of DG based power island. However, regulations need to be modified to take it on board. Future scope of this work is to investigate on hybrid power island with different DGs and storage facility and economically viable options of re-synchronising the power island with the main grid when the situation permits. Any hazard during re-synchronising also need to be critically verified with suitable protection coordination.

ACKNOWLEDGEMENT

The authors are pleased to acknowledge the support provided by The University of Manchester, EPSRC Supergen Project.

REFERENCES

- [1] N.Jenkins, R.Allan, P.A.Crossley, D.Kirschen and G.Strbac, 2000, *Embedded Generation*, IEE Power and Energy Series 31, The IEE (UK).
- [2] A.Bertani et.al, 2003, "Electrical Energy Distribution Networks: Actual Situation and Perspectives for

- Distributed Generation”, *Proc. of CIRED, 17th International Conference on Electricity Distribution*, Barcelona, Spain.
- [3] R.H.Lasseter and P.Paigi, 2004, “Microgrid: a conceptual solution”, *Proc. of Power Electronics Specialists Conference(PESC)*, Aachen, Germany, Vol.6, 4285- 4290.
- [4] N. Hadjsaid, J. F. Canard and F. Dumas, 1999, “Dispersed Generation Impact on Distribution Networks”, *IEEE Computer Applications in Power*.
- [5] CIGRE, 1998, “Impact of increasing contribution of dispersed generation on the power system“, Final Report, Study Committee no. 37.
- [6] T. Moore, 1998, “Emerging Markets for Distributed Resources”, *EPRI Journal*.
- [7] L.Kumpulainen and K.Kauhaniemi, 2004, “Distributed Generation and Reclosing Coordination,” *Proc. of Nordic Distribution and Asset Management Conference, NORDAC 2004*, Espoo.
- [8] J.A. Pecas Lopes, N. Hatzigaryriou, J. Mutale, P. Djapic and N. Jenkins, 2007, “Integrating distributed generation into electric power systems: A review of drivers, challenges and opportunities”, *Electric Power System Research*, Vol.77, 1189-1203.
- [9] F. M. Gatta, F. Iliceto, S. Lauria and P. Masato, 2003, “Modelling and Computer Simulation of in Dispersed Generation in Distribution Networks. Measures to prevent disconnection during system disturbances”, *Proc. of IEEE Power Tech Conference*, Bologna, Italy.
- [10] F.A.Viawan, D.Karlsson, A.Sannino and J.Daalder, 2006, “Protection Scheme for Meshed Distribution Systems with High Penetration of Distributed Generation”, *Proc. of Power System Conference 2006: Advance Metering, Protection, Control, Communication and Distributed Resources*.
- [11] T.Thacker, 2005, *Control of Power Conversion Systems for the Intentional Islanding of Distributed Generation Units*, Thesis for Master of Science in Electrical Engineering, Virginia Polytechnic Institute and State University, Blacksburg, Virginia, USA.
- [12] Econnect, 2001, *Assessment of Islanded Operation of Distribution Networks and Measures for Protection*, ETSU K/EL/00235/REP, 2001.
- [13] M.A.Redfern, J.L.Barrett and O.Usta, 1995, “A New Microprocessor Based Islanding Protection Algorithm for Dispersed Storage and Generation Units”, *IEEE Transactions on Power Delivery*, Vol. 10, No. 3, 1249-1254.
- [14] M.Robitaille, K.Agbossou and M.L.Doumbia, 2005, “Modeling of an Islanding Protection Method for a Hybrid Renewable Distributed Generator”, *Proc. of Electrical and Computer Engineering*, Canada, 1477-1481.
- [15] M.A.Redfern, O.Usta and G.Fielding, 1993, “Protection Against Loss of Utility Grid Supply for a Dispersed Storage and Generation Unit”, *IEEE Transactions on Power Delivery*, Vol. 8, No. 3, 948-954.
- [16] C.G.Bright, 2001, “COROCOF: Comparison of Rate of Change of Frequency Protection : A Solution to the Detection of Loss of Mains”, *Developments in Power System Protection, Conference Publication No. 479 © IEE* 2001.
- [17] Econnect, 2005, *Islanded Operation of Distribution Networks*, DG/CG/00026/00/00.